

FILED 2/18/2020  
DOCUMENT NO. 00964-2020  
FPSC - COMMISSION CLERK

FLORIDA PUBLIC SERVICE COMMISSION  
OFFICE OF COMMISSION CLERK



*[Handwritten signature]* 4/7/2026  
**DECLASSIFIED**

**DOCUMENT NUMBER ASSIGNMENT\***

**FILED DATE:** 2/18/2020  
**DOCKET NO.:** 20200001-EI  
**DOCUMENT NO.:** 00964-2020  
**DOCUMENT DESCRIPTION:**

**CONFIDENTIAL**

TRANSCRIPT (CONFIDENTIAL) - Volume 3, pages 291 to 427, of 2/5/20 final hearing held at DOAH before The Honorable Lawrence P. Stevenson [Case No. 19-006022]. [x-ref DNs 00962-2020, 00963-2020, 00967-2020, 00968-2020, 00969-2020, 00970-2020, 00971-2020, 00972-2020, 00973-2020, 00974-2020, 00975-2020, 00976-2020, 00977-2020, 00978-2020, 00979-2020, 00981-2020, 00982-2020, 00983-2020]

**\*This document number has been assigned to a confidential document.  
For further information, contact the Office of Commission Clerk.**

E-MAIL: [CLERK@PSC.STATE.FL.US](mailto:CLERK@PSC.STATE.FL.US) PHONE NO. (850) 413-6770 FAX NO. (850) 717-0114

1 STATE OF FLORIDA  
2 DIVISION OF ADMINISTRATIVE HEARINGS

3  
4 RE IN: FUEL AND PURCHASED POWER  
5 COST RECOVERY CLAUSE WITH  
6 GENERATING PERFORMANCE INCENTIVE  
7 FACTOR,

8 Petitioner,

9 vs. CASE NO. 19-6022

10 \*\*,

11 Respondent.

12 \_\_\_\_\_/

13 VOLUME 3

14 PAGES 291 - 427

15 PROCEEDINGS: Administrative Hearing

16 BEFORE: Honorable Lawrence P. Stevenson

17 DATE: February 5, 2020

18 TIME: Commenced: 8:55 A.M.

19 LOCATION: Division of Administrative Hearings  
20 1230 Apalachee Parkway  
The DeSoto Building,  
Tallahassee, Florida

21 REPORTED BY: DEBRA R. KRICK  
22 Court Reporter

23 APPEARANCES: (As heretofore noted.)  
24 PREMIER REPORTING  
114 W. 5TH AVENUE  
TALLAHASSEE, FLORIDA  
25 (850) 894-0828

1	INDEX TO WITNESSES	
2	WITNESS	PAGE
	RICHARD A. POLICH	
3	Examination by Mr. David	296
4	Prefiled direct testimony inserted	314
	Examination by Mr. Bernier	342
5	Examination by Ms. Brownless	358
	Examination by Mr. Rehwinkel	363
6	Further Examination by Mr. David	368
7		
	JEFF SWARTZ	
8	Examination by Mr. Bernier	371
9	Prefiled rebuttal testimony inserted	373
	Examination by Mr. Rehwinkel	398
10	Examination by Mr. Moyle	401
	Examination by Mr. Brew	403
11	Further Examination by Mr. Bernier	411
12		
13		
14		
15		
16		
17		
18		
19		
20		
21		
22		
23		
24		
25		

1	INDEX TO EXHIBITS			
2	NO.	DESCRIPTION	IDENTIFIED	ADMITTED
3	101-109	As identified in the		295
4	115	comprehensive exhibit list		
5	116	As previously identified on		295
6	113	the record		
7	110	As previously identified on		295
8	111	the record		
9	117	As identified in the		296
10	68-75	comprehensive exhibit list		
11	112	As identified in the		296
12	118	comprehensive exhibit list		
13	80-82	As identified in the		296
14		comprehensive exhibit list		
15		Revised Exhibit RAP-9	342	342
16		As identified on the		370
17		comprehensive exhibit list		
18		As identified in the		414
19		comprehensive exhibit list		
20		As identified in the	414	414
21		comprehensive exhibit list		
22		As identified in the		415
23		comprehensive exhibit list		
24		As identified in the		
25		comprehensive exhibit list		

\*Huh-uh is a negative response

\*Uh-huh is a positive response

1 P R O C E E D I N G S

2 THE COURT: I will swear you in.

3 Whereupon,

4 RICHARD A. POLICH

5 was called as a witness, having been first duly sworn to  
6 speak the truth, the whole truth, and nothing but the  
7 truth, was examined and testified as follows:

8 THE WITNESS: I do, sir.

9 THE COURT: All right. Have a seat.

10 MR. REHWINKEL: Your Honor, before we get  
11 started with Mr. Polich. Yesterday, when we  
12 concluded, I think everyone was ready to take a  
13 break from engineering 101 yesterday. We neglected  
14 to take care of a housekeeping measure that we  
15 usually do with the Commission, which was after a  
16 witness leaves the stand, his exhibits are moved  
17 in.

18 THE COURT: Exhibits?

19 MR. REHWINKEL: Yeah, so I think Duke needs to  
20 move his, and then we need to address ours.

21 THE COURT: That's fine. I can tell you,  
22 yeah, what I have got here -- well, I thought I had  
23 them here.

24 MR. REHWINKEL: I have his direct.

25 THE COURT: Yeah, what -- the testimony,

1           then -- I am just going through in the order that  
2           these exhibits came up. I have got 115 and 116,  
3           that was I think was Public Counsel's exhibits; is  
4           that right?

5           MR. REHWINKEL: Yes. And I think we would  
6           move actually the earlier -- 101 through 109 were  
7           identified for identification purposes. We would  
8           now move 101 through 109 and 115 and 116 into the  
9           record.

10          MR. BERNIER: So without going through them  
11          individually, Judge, we raised objections to some  
12          of them yesterday as we brought them up, and we  
13          would just stand on those objections and bring them  
14          up again in the PRO.

15          THE COURT: That's fine. We will show them  
16          admitted with the understanding that there are  
17          aspects.

18          So we will show 101 through 109 and 115 and  
19          116 admitted.

20          (Whereupon, Exhibit Nos. 101-109, 115 & 116  
21          were received into evidence.)

22          THE COURT: And let's --

23          MR. BREW: Excuse me, Your Honor. Your Honor,  
24          PCS had offered Exhibit 113 for identification, and  
25          we would move that for admission as well.

1 THE COURT: Okay, and not 112?

2 MR. BREW: We haven't discussed 112 yet.

3 THE COURT: Okay, that's right. That was --  
4 that was your -- okay. So we will show 113  
5 admitted.

6 (Whereupon, Exhibit No. 113 was received into  
7 evidence.)

8 THE COURT: And then I think the Commission  
9 talked about 110 and 111.

10 MS. BROWNLESS: Yes, and we would ask that  
11 that be admitted at this time.

12 THE COURT: We will show 110 and 111 admitted.

13 (Whereupon, Exhibit Nos. 110 & 111 were  
14 received into evidence.)

15 THE COURT: And I think that brings us  
16 up-to-date.

17 The witness has been sworn, and so whenever  
18 Public Counsel is ready.

19 MR. DAVID: Thank you, Your Honor.

20 EXAMINATION

21 BY MR. DAVID:

22 **Q Please state your full name for the record,**  
23 **and spell your last name, please.**

24 A Yes, Richard A. Polich, P-O-L-I-C-H.

25 **Q Thank you.**

1                   **And what is your educational background?**

2           A       I have a Bachelor's in Engineering in  
3 Mechanical Engineering, a Bachelor's in Engineering in  
4 Nuclear Engineering and an MBA, all from the University  
5 of Michigan.

6           **Q       And what is your current occupation?**

7           A       My current occupation is as consultant. Job  
8 title is managing director. I work for a company by the  
9 name of GDS Associates.

10          **Q       And what service or services were you retained  
11 to provide in this case?**

12          A       I was requested by the Florida Office of  
13 Public Counsel to review the failures at Duke Bartow in  
14 regards to the steam turbine, perform an assessment of  
15 those failures and do a calculation of revenues that  
16 could potentially be recovered.

17          **Q       All right. And have you testified as a  
18 witness before in a regulatory proceeding, a utility  
19 regulatory proceeding?**

20          A       Many times.

21          **Q       And can you give us some examples of the  
22 venues in which you have testified?**

23          A       I did a significant amount of worked in  
24 Michigan associated with rate design and regulatory.  
25 Part of that started with Consumers Energy when I was

1 manager of rates. And so I was involved in that in  
2 several aspects both with consumers and also with --  
3 with an entity called Energy Michigan, which oftentimes  
4 was filing in opposition to the utility's.

5 I have also testified in proceedings in  
6 Indiana. It was actually a Duke case involving a  
7 failure of a generator. There is -- I also testified in  
8 Georgia and also at FERC.

9 **Q All right. And did you -- in those, did you**  
10 **appear for the utility, the regulator or --**

11 A A variety of aspects. In Georgia, I was on  
12 behalf of MARTA, which is the transportation  
13 organization in Georgia.

14 In the case of -- I also neglected, I also  
15 testified in North Carolina on behalf of the Attorney  
16 General's Office. And then I have also testified that  
17 the -- the case at FERC involved actually testifying on  
18 behalf of a group of utilities in a reactor power case.

19 **Q And can you give me just a general description**  
20 **of the materials that you used to develop your opinions,**  
21 **or your analysis in this case?**

22 A Yes. In general, I mean, most of the material  
23 that -- okay, 99 percent of the material that I reviewed  
24 was material provided by Duke in discovery, as well as  
25 testimony and various other documents that were made

1 available to me.

2 Q All right. And did you file or cause to be  
3 filed direct testimony in this case on or about  
4 September 13th of 2019?

5 A Yes, I did.

6 Q And did you file or cause to be filed with  
7 that testimony nine exhibits identified on the  
8 comprehensive exhibit list filed within those exhibits  
9 68 through 76, inclusive?

10 A Yes, I believe so.

11 Q All right. And do you have any changes or  
12 revisions to that testimony, or to any of those  
13 exhibits?

14 A Yes, I do.

15 Q What are those?

16 A Okay. The first change is on page seven, line  
17 19, there is a percentage in that line that says  
18 25 percent. I would like to change that to 13 percent.

19 Q Okay.

20 A The second change and all subsequent changes  
21 are associated with the revision to Exhibit 9. After  
22 filing testimony, I was reviewing the calculations I  
23 used for determining the replacement power costs that --  
24 that -- that -- associated with the derated Duke of the  
25 Bartow unit, and I discovered that inadvertently my

1 calculations had included the replacement power costs  
2 during the time periods when the plant as in an outage.  
3 And so I deleted those costs from the calculations and  
4 it resulted in changes in both the recommended amount of  
5 the cost that could potentially be recoverable.

6 And so going to page nine, the first change  
7 associated with that is on page nine, line two. The  
8 sentence reads right now: Caused by installation of the  
9 pressure plate is over 16.84 million. I would like to  
10 change that to, after the word is around 12 million.

11 **Q What was -- excuse me, could you clarify that**  
12 **again? Is from installation of the pressure plate is**  
13 **over --**

14 A Is around 12 million.

15 **Q 12, okay.**

16 A I am sorry. No, 16 point -- 16 million. I am  
17 sorry. 16 million.

18 **Q Okay. So just for clarity, is over 16.12**  
19 **million, is that what you were --**

20 A Yes. There is two -- I worded it as around  
21 16 million.

22 **Q Oh, okay.**

23 MS. BROWNLESS: Excuse me, can you just read  
24 that whole sentence the way it ought to be?

25 THE WITNESS: Okay, I can. Yes.

1           The replacement -- the sentence which begins  
2           on line one should read: The replacement power  
3           costs associated with the 2017 outage and derate  
4           caused by installation of the pressure plate is  
5           around 16 million.

6           Sorry for the confusion.

7           Moving to the next set of changes, starting on  
8           line -- on page 27, starting on line five, there is  
9           a figure of 2,005,536. That figure should be  
10          1,675,561.

11          On the next line, on line six, there is a  
12          megawatt figure of 162,040. That figure should be  
13          150,400.

14          All right. Moving to line 12, there is a  
15          dollar amount of 2,545,049. That number should be  
16          changed to 2,215,648. There is also a megawatt  
17          figure on that same line of 213,280. That number  
18          should be changed to 199,680.

19          Moving to line 20, there is a dollar amount of  
20          that 1,189,552. That number should be changed to  
21          1,125,573. The megawatt figure on that line of  
22          128,480 should be changed to 125,800.

23          And the last change is on page 28, line four.  
24          There is a dollar amount in there of 16.84 million.  
25          That figure should be changed to 16,116,701 -- 781.

1 BY MR. DAVID:

2 Q Okay. Are those all the changes you have  
3 to --

4 A In addition, there should be a revised Exhibit  
5 9.

6 Q Correct, okay.

7 The RAP exhibits -- I mean, identified in your  
8 testimony as RAP-9 and identified on the comprehensive  
9 exhibit list as 76 has corresponding calculation  
10 changes?

11 A Yes.

12 Q Okay. Okay. And with all of those changes  
13 made, if I asked you today the same questions as I asked  
14 in your direct testimony, would your answers be the same  
15 other than, of course, like I said, the aforementioned  
16 changes?

17 A Yes, they would.

18 Q And the changes that were made to CLE  
19 exhibit -- CEL exhibit, excuse me, 76, RAP-9, did you  
20 supply that information before today to, in discovery,  
21 to Duke and staff?

22 A I believe we have.

23 Q Are you prepared to give a summary of your  
24 testimony and its conclusions?

25 A Yes, I am.

1           **Q     Okay. Go ahead.**

2           A     Okay. To understand my testimony, it's  
3 important to understand some of the background of the  
4 Bartow project, as well as how it's been configured.  
5 And what this leads towards is the fact that the  
6 statement contained in my testimony that 420-megawatt  
7 output is a design limit on which the Bartow plant was  
8 designed.

9                     Having designed thermal cycles for multiple  
10 power plants, the designer always wants to gets the  
11 maximum output for a given plant investment at the best  
12 heat rate. It's a fundamental principle of what you do  
13 in design. It has to do with how you put the project  
14 together and what you want to do with it.

15                    The Bartow project was Progress Energy's first  
16 combined cycle project and would have -- and they would  
17 have wanted the most output for their investment. They  
18 had already decided on installing four CTs when three  
19 would have sufficed to power the Mitsubishi turbine.

20                    One of the things about this design is that  
21 you can fully power that steam turbine with three  
22 combustion turbines and heat recovery steam generators.

23                    Can I approach the Exhibit for a second here?

24                    THE COURT: Sure.

25                    THE WITNESS: All right. So the way this

1 project is designed is you have four of these.  
2 Four combustion turbines and four heated recovery  
3 steam generator, and of course, all the ancillary  
4 services supplying steam to just one steam turbine.

5 And this project was designed such that you  
6 could provide all the steam requirements for this  
7 and produce 420 megawatts with just three CTs and  
8 HRSGs. So essentially, you have 25 percent  
9 redundancy. You also have 25 percent additional  
10 steam available to put into the steam turbine.

11 And if that were the case, as a designer, and  
12 as Progress Energy, in terms of designing this  
13 project and putting it forth before the Public  
14 Service Commission, you want to build a project and  
15 tout its dollars per kW as low as possible, because  
16 it shows the value of the project. You as the  
17 designer want to develop a project that, for every  
18 dollar you are putting into it, produces the  
19 maximum amount of megawatts.

20 With as much steam capability to power the  
21 steam turbine, if that unit could produce  
22 450 megawatts, the designer and the utility would  
23 have wanted that from day one.

24 They, Kiewit and -- Bibb/Kiewit performed over  
25 300 different heat analyses of how this whole thing

1 is going to work. Not one of those analyses ever  
2 showed this steam turbine producing more than  
3 420 megawatts. If that steam turbine had that  
4 capability, they would have produced a thermal  
5 analysis to that effect.

6 Bibb worked very close with Mitsubishi on how  
7 this whole process works. There is correspondence  
8 between Bibb and Mitsubishi as to what this package  
9 can put out. There was information about how much  
10 steam can go to -- can be provided.

11 Mitsubishi responded with this is the output.  
12 420 megawatts was a design limit. If Mitsubishi  
13 thought this unit could produce more, they would  
14 have told Bibb that and they would have designed it  
15 with higher output.

16 You had a case where this was an aftermarket  
17 unit. It was not designed to handle the amount of  
18 steam that was built that was available to this  
19 steam turbine. It was designed for a much smaller  
20 steam flow. And it is my experience that  
21 Mitsubishi knew that there were limitations as to  
22 how much power and steam this could take, and that  
23 they factored that into how this plant was  
24 designed. And so did the EPC Kiewit/Bibb. This is  
25 a critical issue, because Duke has contended very

1           often and throughout their testimony that  
2           420 megawatts was not a design condition.

3           Now, I have worked in this industry many, many  
4           years, too many to tell sometimes, but the fact  
5           that this proj-- that you had so much steam  
6           available gives you amazing amount of flexibility  
7           in how you operate it. And I think this is a great  
8           plant design. Don't get me wrong, but there are  
9           limits. And when you have a plant of this type, of  
10          this type of design, you, as an operator, have to  
11          be careful as to how you utilize that capability.

12          It is my feeling that, and my experience that  
13          when you have a situation like this, it is  
14          important that you understand how it's going to  
15          function. And if you discover that, hey, you know,  
16          I can get potentially more out of this, you should  
17          always pause, because steam turbines have a lot of  
18          forces and dynamics that are happening inside of  
19          them that we've discovered afterwards, you know.

20          And I agree that some of this analysis work is  
21          all, you know, after-the-fact, but fundamentally,  
22          you have a responsibility to contact the OEM and  
23          ask a single question, can I get more out of this  
24          unit?

25          It's an insurance policy, because you get an

1           answer that if, yes -- if the OEM comes back and  
2           says, yes, you can get more out of this and it  
3           breaks, then the issue is on their shoulders. It's  
4           an insurance policy. A simple question, get it in  
5           writing and then the issue is settled.

6                     If Duke had done that, we would not be here  
7           today, in simple terms, because the onus would have  
8           been on Mitsubishi at that point. It would have  
9           been totally their responsibility. The fact that  
10          Duke did not do that is a fundamental flaw in what  
11          they chose to -- how they chose to operate this  
12          unit.

13                    And other projects I have been associated  
14          with -- I have a project in Arkansas that we  
15          oversee, and they had a steam turbine that was  
16          designed for 670 megawatts. That was the design  
17          conditions. We went through a turbine upgrade  
18          recently -- or a refurbishment I should say, a  
19          standard outage.

20                    We came out of that outage and discovered we  
21          had the potential for more megawatts out of that  
22          unit. It was only 10 megawatts, so we went from  
23          670 to 680. Before we did that, we contacted the  
24          manufacturer of the steam turbine and said, do we  
25          have any problems if we do this? We got the

1 insurance policy, proceeded to upgrade the oper--  
2 the operate output of the plant. It's just  
3 something you should do.

4 And other projects I have been associated  
5 with -- utilities will push a steam turbine, and I  
6 understand that. It's a legitimate thing to do  
7 because it's cheap capacity. But you also have  
8 responsibility to get back with the OEM and verify  
9 that there isn't something inside of that unit that  
10 will break if you do it. And this is a fundamental  
11 issue in my testimony.

12 The other thing, too, is that the reason why I  
13 am strongly of the opinion that 420 was the  
14 megawatt limit is that when Duke finally did ask  
15 Mitsubishi, can we produce more than 420 megawatts?  
16 Mitsubishi said, we need to do a study for that.  
17 They came back and proposed a dollar amount that --  
18 of -- in one that says we don't know, we need to  
19 study this.

20 Again, that tells me that Mitsubishi felt they  
21 had a limit on this unit. And to -- and so I  
22 don't -- I feel that that should have been an  
23 operating condition from day one.

24 All right. If Duke had paused before going  
25 after 420 and asked Mitsubishi if the steam turbine

1           could operate above 420 megawatts, and put it in  
2           writing, as I said, this would just take this whole  
3           issue off the table.

4                     Instead, Duke ignored the red line on the  
5           unit, and they took their Ferrari and ran it, and  
6           something broke, but the interesting thing is it  
7           didn't break right away, all right.

8                     If you look at what happened in Periods 1 and  
9           2, they operated that unit for 62 months between  
10          the two periods, approximately 43,000 hours of  
11          operation, using the Type 1 blades, and only saw  
12          minor damage. And, in fact, on the generator  
13          end -- I am going to approach the diagram again.

14                    We talked yesterday about the fact that we  
15          have one set of L0 blades here and one set here.  
16          These L0 blades during Periods 1 and 2 had no  
17          failures, even though this unit had been operated  
18          at 450 megawatts for over 2,000 hours at  
19          significant stresses much higher than what the  
20          manufacturer had ever seen in any of their L0  
21          blades.

22                    And it is our contention that if you had not  
23          overstressed those blades, there is no evidence  
24          that those blades would not still be in operation  
25          today.

1 Duke contends that, you know, that what  
2 happened in Period 5 when you put the L1 -- the  
3 Type 1 blades back in, is evidence that this is not  
4 a true fact. But let's look at some issues here.

5 Those Type 1 blades in Period 5 failed in  
6 1,561 hours of operation. That's less than four  
7 percent of the hours that those same set of blades  
8 were able to operate in Periods 1 and 2. The  
9 reason why that's significant is -- and the other  
10 thing is that those Type 1 blades that they put in  
11 in that time period failed quicker than any of the  
12 other blades that they put in.

13 MR. BERNIER: Your Honor, I apologize, but I  
14 have to object. Nowhere does this testimony that  
15 he is summarizing appear in his direct testimony.  
16 I believe that is what we are doing here is,  
17 summarizing his direct testimony. This simply does  
18 not appear there. And that is the practice that we  
19 follow in front of the Commission, which I think we  
20 all agreed is what we are here to do.

21 THE COURT: So far I am only hearing him sort  
22 of do the math. I mean, if he goes beyond that and  
23 come to some different conclusion than he said in  
24 his testimony, I might be inclined to strike it,  
25 but so far he is just -- you know what I am saying,

1           this all sounds like stuff he is pulling out and  
2           just doing the numbers.

3           MR. BERNIER: I do understand what you are  
4           saying, Judge, and not to be argumentative, but he  
5           is now rebutting the rebuttal testimony to his  
6           testimony, and there is simply not -- that is not  
7           part of his direct testimony.

8           If that's something that's solicited on cross,  
9           that's one thing, but that is not something that he  
10          has provided any testimony to in writing, so he has  
11          just gone beyond the scope.

12          MR. REHWINKEL: Your Honor, we would -- I  
13          would, to some degree, acknowledge Mr. Bernier's  
14          point, but yesterday, Mr. Swartz took great  
15          liberties.

16          For us, in a proceeding where the judge is not  
17          intimately familiar with the way the Public Service  
18          Commission operates or the issues on a day-to-day  
19          basis, we thought it was appropriate for Mr. Swartz  
20          to take great liberties to expand on his testimony,  
21          and I think Mr. Polich is doing the same thing.

22          It probably would be a good time for us to  
23          conclude his summary and go to cross-examination.

24          THE COURT: Okay. That sounds like a plan  
25          then.

1 THE WITNESS: All right. So let me cut to  
2 this -- move forward on this.

3 So in my analysis, I looked at all of the  
4 information that was provided in Duke's root cause  
5 analysis, and I felt that there was a fatal flaw in  
6 that analysis, and that is why I came to the  
7 conclusion that you have to look at what happened  
8 in Period 1.

9 And the fatal flaw in their analysis is the  
10 fact that Period 1 and 2 was an outlier. The  
11 blades lasted longer during those two periods than  
12 in any other period of operation of this unit.  
13 Nowhere in Duke's RCA do they explain why those  
14 blades lasted so long. All their RCA addresses  
15 all -- is just the failures.

16 And in my testimony, I came to the conclusion  
17 that that is a very important factor in the  
18 operation of this unit. There was something about  
19 those blades' designs in Period 1 that allowed them  
20 to last longer. There is something about those  
21 blades that the Period 5 blades were not identical  
22 enough to last as long.

23 And it is for this reason that we came to the  
24 conclusion that the failures in Period 1 were due  
25 to overstressing the unit by putting too much steam

1 through it and operating at 420 -- in excess of  
2 420 megawatts, and that Duke should be responsible  
3 for the replacement power costs.

4 MR. DAVID: Thank you.

5 Your Honor, I would like to move Mr. Polich's  
6 direct testimony into evidence, please. And after  
7 that, I would tender him for cross-examination.

8 THE COURT: Show that done.

9 (Whereupon, prefiled testimony was inserted.)  
10  
11  
12  
13  
14  
15  
16  
17  
18  
19  
20  
21  
22  
23  
24  
25

**DIRECT TESTIMONY****OF****RICHARD A. POLICH, P.E. (STATE OF MICHIGAN)**

On Behalf of the Office of Public Counsel

Before the

Florida Public Service Commission

Docket No. 20190001-EI

1 **I. INTRODUCTION**2 **Q. PLEASE STATE YOUR NAME, TITLE AND BUSINESS ADDRESS.**

3 A. My name is Richard A. Polich. I am a Managing Director at GDS Associates,  
4 Inc. ("GDS"). My business address is 1850 Parkway Place, Suite 800, Marietta,  
5 Georgia, 30067.

6

7 **Q. WHAT ARE YOUR DUTIES AND RESPONSIBILITIES AT GDS**  
8 **ASSOCIATES?**

9 A. My primary duties are within GDS's Power Supply Planning Department.

10 While employed by GDS, I have provided consulting services for areas such as:

- 11 • Generation Asset Management,  
12 • Engineering analysis of generation projects,  
13 • Engineering evaluation of waste to energy projects,  
14 • Energy management consulting services,  
15 • Nuclear decommissioning cost evaluation,  
16 • Modular nuclear project cost evaluation,  
17 • Renewable energy project cost assessment and economic evaluation,  
18 • Testimony on rate of return, cost of service, regulatory disallowances,  
19 determination of prudence, revenue requirements and plant in service, and  
20 • Review of generation project design and construction.

1 **Q. MR. POLICH, PLEASE SUMMARIZE YOUR FORMAL EDUCATIONAL.**

2 A. I graduated from the University of Michigan - Ann Arbor in August 1979 with  
3 a Bachelor of Science Engineering Degree in Nuclear Engineering and a Bachelor of  
4 Science Engineering Degree in Mechanical Engineering.

5  
6 **Q. PLEASE BRIEFLY DESCRIBE YOUR PROFESSIONAL EXPERIENCE.**

7 I have over 40 years of work experience in the energy sector, performing duties  
8 and services for a myriad of companies and organizations, and representing the interests  
9 of private and public constituencies throughout the country.

10 In May 1978, I joined Commonwealth Associates, Inc., located in Jackson,  
11 Michigan, as a Graduate Engineer and worked on several plant modification and new  
12 plant construction projects.

13 In May 1979, I joined Consumers Power Inc., (now called Consumers Energy),  
14 located in Jackson, Michigan, as an Associate Engineer in the Plant Engineering  
15 Services Department.

16 In April 1980, I transferred to the Midland Nuclear Project and progressed  
17 through various job classifications to Senior Engineer. I was also part of a small team  
18 that evaluated the potential to repower the nuclear steam turbine with combustion  
19 turbines. One of my responsibilities was to provide the initial thermal design for the  
20 combined cycle project, utilizing one of the two existing nuclear steam turbines while  
21 still providing process steam for Dow Chemical Company. This project is now known  
22 as the Midland Cogeneration Venture, a 12-combustion turbine and steam turbine  
23 project capable of providing 1,633 MW of capacity.

1           In July 1987, I transferred to the Market Services Department as a Senior  
2 Engineer and reached the level of Senior Market Representative. While in this  
3 department, I analyzed the economic and engineering feasibility of customer  
4 cogeneration projects.

5           In July 1992, I transferred to the Rates and Regulatory Affairs Department of  
6 Consumers Energy as a Principal Rate Analyst. In that capacity, I performed studies  
7 relating to all facets of development and design of Consumers Energy's gas, retail,  
8 electric and electric wholesale rates. During this period, I was heavily involved in the  
9 development of Consumers Energy's Direct Access program and in the development  
10 of Consumers Energy's Retail Open Access program. I also participated in the  
11 development of Consumers Energy's revenue forecast.

12           In March 1998, I joined Nordic Energy, LLC ("Nordic"), located in Ann Arbor,  
13 Michigan, as Vice President in charge of marketing and sales. My responsibilities  
14 included all aspects of obtaining new customers and enabling Nordic to supply  
15 electricity to those customers. In May 2000, my responsibilities shifted to Operations  
16 and Regulatory Affairs and my responsibilities included management of supply  
17 purchases, transmission services, and development of new power projects. My  
18 Regulatory Affairs responsibilities also included overseeing regulatory and legislation  
19 issues for the company.

20           In March 2003, I formed Energy Options & Solutions, based in Ann Arbor,  
21 Michigan, as a consulting concern focusing on providing engineering services and  
22 regulatory support. Through my work with Energy Options & Solutions, I gained  
23 extensive experience consulting in the areas of project development and economic

1 analysis with renewable energy companies across the country, including: Noble  
2 Environmental Power located in Centerbrook, Connecticut; Third Planet Windpower,  
3 LLC located in Palm Beach Gardens, Florida; TradeWind Energy, LLC located in  
4 Lenexa, Kansas; Windlab Developments USA located in Canberra, Australian Capital  
5 Territory, Australia; and Matinee Energy Inc. located in Tucson, Arizona, among  
6 others.

7 Other examples of my consulting work include evaluation of the Arkansas  
8 Weatherization Assistance Program for the Arkansas Energy Office and providing the  
9 West Michigan Business Alliance with an evaluation of the business opportunities for  
10 Western Michigan businesses in the renewable energy business sector.

11 In 2007, I served as primary author of a report on the economic impacts of  
12 renewable portfolio standards and energy efficiency programs for the Department of  
13 Environmental Quality – State of Michigan.

14 In 2011, I joined KEMA, Inc. (“KEMA”) located in Burlington, Massachusetts,  
15 as a Service Line Leader responsible for developing its renewable energy consulting  
16 business. While at KEMA, I performed multiple renewable energy studies for the  
17 Electric Power Research Institute, including a renewable energy options study for the  
18 country of Saint Maarten (a constituent country of the Kingdom of the Netherlands). I  
19 also assisted Lake Erie Energy Development Corporation in its successful application  
20 to the U.S. Department of Energy for a multi-million dollar grant to develop an offshore  
21 wind project in Lake Erie.

22 In 2013, I joined CLEAResult, located in Little Rock, Arkansas, as Director of  
23 Operations. My primary responsibility involved supporting program operations in

1 assisting the company's Arkansas unit to successfully meet a 400% increase in energy  
2 efficiency goals that it managed for Entergy. I was also responsible for managing the  
3 company's natural gas energy efficiency programs in the State of Oklahoma.

4 In 2015, I joined the Georgia office of GDS Associates, Inc., a consulting group  
5 focusing on utility engineering and consulting services, as Managing Director.

6 I have been a registered Professional Engineer since 1983 and I am licensed in  
7 the State of Michigan.

8 My resume is included as Exhibit No. \_\_\_(RAP-1).

9

10 **Q. HAVE YOU TESTIFIED IN OTHER REGULATORY PROCEEDINGS?**

11 A. Yes, Exhibit No. \_\_\_(RAP-2) contains a list of regulatory proceedings in which  
12 I have provided testimony.

13

14 **Q. WHAT IS THE NATURE OF YOUR BUSINESS?**

15 A. GDS Associates, Inc. ("GDS") is an engineering and consulting firm with  
16 offices in Marietta, Georgia; Austin, Texas; Corpus Christi, Texas; Manchester, New  
17 Hampshire; Madison, Wisconsin; Manchester, Maine; and Auburn, Alabama. GDS  
18 provides a variety of services to the electric utility industry including power supply  
19 planning, generation support services, rates and regulatory consulting, financial  
20 analysis, load forecasting and statistical services. Generation support services provided  
21 by GDS include fossil and nuclear plant monitoring, plant ownership feasibility studies,  
22 plant management audits, production cost modeling and expert testimony on matters

1 relating to plant management, construction, licensing and performance issues in  
2 technical litigation and regulatory proceedings.

3

4 **Q. WHOM DO YOU REPRESENT IN THIS PROCEEDING?**

5 A. I am representing the Florida Office of Public Counsel (“OPC”).

6

7 **Q. WHAT WAS YOUR ASSIGNMENT IN THIS PROCEEDING?**

8 A. I was asked by the OPC to conduct a review and evaluation of Duke Energy  
9 Florida, LLC’s (“DEF’s”) operation of the Bartow Combined Cycle Power Plant  
10 (“BCC”) located in Pinellas County, Florida. The review and evaluation included  
11 assessment of the BCC steam turbine (“ST”) mechanical problems which led to several  
12 outages and derates. My testimony also includes an assessment of replacement power  
13 costs for 2017 and 2018, an estimate for part of 2019 associated with periods in which  
14 the BCC was not available to provide full capacity, and the cost of that replacement  
15 power that DEF is seeking to recover from its ratepayers in this proceeding.

16

17 **Q. DID OTHER GDS PERSONNEL ASSIST YOU IN THE ANALYSIS AND**  
18 **DEVELOPMENT OF YOUR TESTIMONY IN THIS MATTER?**

19 A. No.

20

21 **Q. ARE YOU SPONSORING ANY EXHIBITS?**

22 A. Yes, I am sponsoring the following exhibits:

23 1. Exhibit No. \_\_\_(RAP-1) Richard A. Polich, P.E. Resume

- 1           2. Exhibit No. \_\_\_(RAP-2) Richard Polich Regulatory Testimony List
- 2           3. Exhibit No. \_\_\_(RAP-3) Bartow Combined Cycle Thermal Cycle
- 3           4. Exhibit No. \_\_\_(RAP-4) Turbine Generator Output Curve
- 4           5. Exhibit No. \_\_\_(RAP-5) BCC ST Operation Greater than 420 MW
- 5           6. Exhibit No. \_\_\_(RAP-6) Bartow ST#1 L0 Blade Upgrade to Achieve 450 MW,
- 6                 dated September 18, 2013
- 7           7. Exhibit No. \_\_\_(RAP-7) Bartow RCA Review, dated March 15, 2017
- 8           8. Exhibit No. \_\_\_(RAP-8) Update on 40" Last Stage Blade, dated 2015
- 9           9. Exhibit No. \_\_\_(RAP-9) Bartow Combined Cycle Replacement Power Costs

10

11   **II.   TESTIMONY SUMMARY**12   **Q.   PLEASE SUMMARIZE YOUR TESTIMONY.**

13   A.           My review of various documents provided by DEF regarding the BCC low  
14                 pressure turbine L0 blade failures reveals that the cause of the blade failures initially  
15                 experienced in 2012 was DEF's operation of the BCC ST beyond the ST's 420 MW  
16                 design. The Root Cause Analysis ("RCA") provided by the steam turbine manufacturer,  
17                 Mitsubishi Hitachi Power Systems ("MHPS"), explains that Duke's operation of the  
18                 BCC ST to produce sufficient horsepower to generate more than 420 MW, subjected  
19                 the L0 blades to forces that were ~~25%~~ **13%** higher than the designed operating conditions.  
20                 DEF operated the ST at BCC in excess of 420 MW from June 2009 until the February  
21                 2012 outage for a combined 2,973 hours. As of the time of filing this testimony, DEF  
22                 has failed to provide any documentation that demonstrates they communicated with

**Court  
Reporter:  
DK**

1 MHPS about operation of the ST in excess of 420 MW, until after the failure of the L0  
2 blades was discovered.

3 DEF operated the BCC ST with the original design L0 blades for 63 months  
4 after the plant entered initial operation—a period of only slightly over five years. After  
5 the February 2012 outage, DEF operated BCC in a manner that generated an ST output  
6 at or below the design of 420 MW with the original design L0 blades, for an additional  
7 28 months (within that first 63 months of operation). Inspection of these L0 blades in  
8 2014 did not find snubber or z-lock damage as was found in February 2012. The  
9 additional stresses on the L0 blades caused by DEF's operation of the ST in a manner  
10 that generated output above the 420 MW design conditions impacted the L0 blades in  
11 a way that shortened blade life. If DEF had operated the ST at BCC in accordance with  
12 design output of 420 MW or less, I believe there is no engineering basis to conclude  
13 that the original L0 blades would not still be in operation today. Likewise, DEF would  
14 not have needed to undertake any of the subsequent outages to repair L0 blades,  
15 including the outage in February 2017 to replace the L0 blades with the pressure plate.  
16 Consequently, the BCC ST would currently be capable of producing its full output of  
17 420 MW instead of being derated to 380 MW and operating with a less-than-optimal  
18 pressure plate.

19 As a result of the 2017 outage and the 40 MW reduction in BCC ST output  
20 (derate) due to installation of the pressure plate, DEF incurred power costs for the  
21 replacement MWh. DEF has failed to demonstrate that ratepayers should be responsible  
22 for these costs since the 2017 outage and subsequent derate were the result of DEF  
23 imprudently operating the BCC ST in excess of the manufacturer's 420 MW design

1 conditions. The replacement power costs associated with the 2017 outage and derate  
2 ~~caused by installation of the pressure plate is over \$16.84 million.~~ **is around 16 million** The Florida Public  
3 Service Commission should not allow DEF to recover these costs from its rate payers.

**Court  
Reporter:  
DK**

4

5 **Q. PLEASE DEFINE THE TERM “DERATE” AS USED IN CONNECTION WITH**  
6 **REDUCTION IN ST OUTPUT.**

7 A. Derate is a term commonly used in the utility industry when a generation facility  
8 is unable to generate MW at its normal operating level. The reduction in generation  
9 output is usually temporary and caused by equipment degradation or failures. For the  
10 purposes of my testimony, I will be using the term “derate” specifically to refer to  
11 reduction in the BCC ST generation capability from 420 MW to 380 MW. This is a  
12 derate of 40 MW for the BCC ST.

13

14 **III. DESCRIPTION OF BCC POWER PLANT**

15 **Q. PLEASE PROVIDE A GENERAL DESCRIPTION OF THE**  
16 **CONFIGURATION OF DEF’S BARTOW COMBINED CYCLE PLANT.**

17 A. BCC is commonly referred to as a 4-on-1 combined cycle plant composed of  
18 four Siemens SGT6-5000-FD3 combustion turbines/generators (“CTs”) and one  
19 Mitsubishi Hitachi Power Systems steam turbine/generator. Exhibit \_\_\_ (RAP-3)  
20 shows the general configuration of BCC. Each CT is capable of producing almost 230  
21 MW gross output with injection of steam into the CT for power augmentation. Non-  
22 steam augmented power output of each CT is in the range of 180 MW. The exhaust of  
23 the CT enters a Voit Power VPPR2 heat recovery steam generator (“HRSG”) that

1 produces steam to power the ST and provide steam augmentation to the CTs. The  
2 HRSG is composed of three different pressure sections: a high pressure (“HP”) section  
3 (approximately 3,000 psig maximum), an intermediate pressure (“IP”) section  
4 (approximately 1,100 psig maximum) and a low pressure (“LP”) section  
5 (approximately 135 psig maximum). Steam production in the HRSG can be increased  
6 by using installed natural gas fired “duct burners” located within the HRSG. The ST  
7 was designed to produce 420 MW gross generation. Exhaust steam from the ST enters  
8 a condenser where the steam is cooled to liquid phase and then pumped back into the  
9 HRSG. The generator output appears to have an upper gross generation limit of about  
10 465 MW at a 0.95 power factor based upon the output curves in Exhibit No. \_\_\_\_ (RAP-  
11 4).

12  
13 **Q. PLEASE PROVIDE A GENERAL DESCRIPTION OF THE BCC STEAM**  
14 **TURBINE.**

15 A. The BCC ST contains three turbine sections, a generator, and various other  
16 components used to control steam flow and operate the ST. HP steam from the HRSG  
17 is first injected into the HP section of the steam turbine through the turbine control  
18 valves. Exhaust steam from the ST HP section is sent back to the HRSG IP section to  
19 be reheated and then sent back to the IP section of the ST. Exhaust steam from the IP  
20 section of the ST then combines with steam from the HRSG LP section to enter the LP  
21 section of the ST, exiting through the last set of turbine blades into the condenser.

1 **Q. PLEASE PROVIDE A GENERAL DESCRIPTION OF THE BCC LP ST**  
2 **SECTION.**

3 A. The BCC LP ST section is a tandem flow ST with steam entering the middle  
4 and flowing in opposite directions through mirror image LP sections. Each side of the  
5 LP ST has four sets of blades, the last of which is the 40” L0 blade set that has  
6 experienced the failures.

7  
8 **IV. OPERATING DESIGN OF BCC STEAM TURBINE**

9 **Q. WHAT FACTORS ARE CRITICAL TO THE DESIGN OF A STEAM**  
10 **TURBINE?**

11 A. Steam turbine design begins with the end users desired gross MW output and  
12 the steam characteristics available to power the steam turbine. The design conditions  
13 considered during the initial ST design include maximum steam pressure, temperature  
14 and flow rate. From this, the ST manufacturer will work with the project thermal design  
15 engineer to develop a set of HP, IP, and LP steam conditions that maximize ST  
16 efficiency, minimize water content of the steam within the ST, and are capable of  
17 allowing the ST to produce the desired MW output. There are a myriad of HP, IP, and  
18 LP steam conditions for steam turbine design that allow production of a given MW.  
19 Experience in plant and ST design, manufacturer-available ST packages, and  
20 engineering parameters reduce the number of solutions, sometimes to one.

1 **Q. WAS THIS THE APPROACH USED FOR THE BCC PROJECT?**

2 A. No. Progress Energy, the original owner of BCC, purchased a “secondary  
3 market” steam turbine that was designed and manufactured for a Tenaska combined  
4 cycle project. However, the ST was never installed for that project and was instead  
5 placed in storage by MHPS. The steam turbine was already constructed—presumably  
6 to meet the needs of Tenaska—so the design parameters were already fixed when it  
7 was purchased by Progress Energy, DEF’s predecessor. Therefore, as DEF knew or  
8 should have known, intractable design limitations were incorporated into the as-built  
9 ST. Discussions with MHPS apparently led Progress Energy, now DEF (references to  
10 DEF through the remainder of this testimony interchangeably refers to Progress Energy  
11 and Duke Energy Florida), to determine this steam turbine generator package would be  
12 suitable for use in the BCC project. These discussions led to a project design in which  
13 the ST maximum gross output was to be 420 MW. None of the analyses of ST  
14 operations performed by MHPS ever showed the ST package producing more than 420  
15 MW.

16  
17 **Q. WHY IS IT IMPORTANT THAT THE ST PACKAGE DESIGN ANALYSES  
18 ONLY INDICATED A MAXIMUM OUTPUT OF 420 MW WHEN THE  
19 GENERATOR WAS CAPABLE OF POTENTIALLY PRODUCING 465 MW.**

20 A. Steam turbine internal components are subjected to steam conditions which  
21 cause significant stress, erosion, and other dynamics which the manufacturer has  
22 incorporated into the component design. Gross MW output is directly proportional to  
23 the horsepower the ST produces. As with a car engine, parts in the ST are designed to

1 provide that horsepower on a basis that is reliable and does not induce failure.  
2 Otherwise, increasing the ST horsepower output can only be accomplished by placing  
3 higher stresses and dynamic forces on the ST components. In most turbines, one of the  
4 critical components subject to very high stress and steam induced dynamics are the  
5 turbine blades. The turbine blades are connected to the turbine shaft, which spins at  
6 3,600 RPM in the BCC ST. The steam impinging on these blades exerts pressure and  
7 dynamic forces that are not uniform. This lack of uniformity may be caused by the  
8 spinning turbine blades, the way the steam is channeled to impinge on the blades, the  
9 changes in steam characteristics between sets of blades, and the formation of water in  
10 the steam as pressure and temperature drop. In addition, a ST does not always run at  
11 full load and steam does not always have the same characteristics throughout the  
12 operating load range as it does at full load. The ST manufacturer understands and takes  
13 these steam dynamics into consideration and designs the ST blades to function without  
14 failure over the design life of the blade, presuming the ST is operated within the  
15 manufacturer's design conditions. It should also be understood that it is standard within  
16 the industry for the manufacturer to include a level of design margin into the ST  
17 components. Some of these design margins are mandated by code; others are based on  
18 experience with operation and manufacturing processes and the expectation that higher  
19 stresses likely will be placed on components when the power plant experiences an upset  
20 such as a plant trip. This is why a ST package designed for 420 MW may not be able  
21 to operate above the horsepower level needed to produce 420 MW without inducing  
22 component failure. Component failure may not occur or be discovered right away, but

1 the component life will be reduced and the increased likelihood of failure is introduced  
2 into the ST at especially susceptible places—like the L0 blades.

3

4 **V. OPERATION OF BCC ST UP THROUGH FEBRUARY 2012**

5 **Q. PLEASE DESCRIBE THE TYPICAL STARTUP AND TESTING**  
6 **PROCEDURES FOR A POWER PROJECT SUCH AS BCC.**

7 A. In early 2009, the BCC project began operation prior to the commercial  
8 operation date. Typical of a new power generation project, the plant proceeded through  
9 various systems testing and progressed through various phases of testing of the CTs  
10 and ST, including raising the ST MW generation up to designed output of 420 MW.  
11 Also, during the testing and startup period or shortly after the project is declared to be  
12 in commercial operation, various components will undergo testing to see if the  
13 equipment meets specific guaranteed operating conditions contained in the equipment  
14 contracts. Steam turbines go through a rigorous testing in accordance with American  
15 Society of Mechanical Engineers (“ASME”) test procedures to determine if the ST  
16 meets the contractual performance guarantees. Based upon information provided by  
17 DEF, the BCC ST was subjected to the ASME test procedures, and MHPS reported on  
18 the June 16, 2009, test that the BCC ST met its guaranteed gross output of 420 MW.

19

20 **Q. HOW WAS THE BCC ST OPERATED IN 2009 AFTER THE PLANT**  
21 **ENTERED COMMERCIAL OPERATION?**

22 A. In June 2009, the BCC ST maximum output was 404.3 MW in accordance with  
23 data provided by DEF, as shown in Exhibit No. \_\_\_ (RAP-5). In July 2009 DEF

1 operated the ST for approximately 23.3 hours in excess of 420 MW design conditions  
2 and in August 2009 for approximately 27.2 hours, reaching a maximum output of 429.2  
3 MW. DEF operated the ST in excess of 420 MW for approximately 374.2 hours in  
4 September and October of 2009, with peak generation of approximately 440 MW. In  
5 November 2009, DEF operated the ST at maximum output of 440.2 MW. In summary,  
6 for calendar year 2009, DEF operated the BCC ST for approximately 433.2 hours in  
7 excess of 420 MW, peaking at 4.8% over design conditions.

8

9 **Q. HOW DID DEF OPERATE THE BCC ST DURING 2010?**

10 A. Compared to 2009, DEF significantly increased the BCC ST output in January  
11 2010 with the unit producing a maximum output of 446 MW, 6.3% higher than design  
12 conditions. DEF operated the BCC ST in excess of 420 MW during each month in 2010  
13 through November, with a maximum output of almost 455 MW, over 8% higher than  
14 design conditions. In total, the BCC ST was operated approximately 940.3 hours in  
15 excess of 420 MW in 2010.

16

17 **Q. HOW DID DEF OPERATE THE BCC ST DURING 2011?**

18 A. DEF operated BCC ST in excess of 420 MW during every month except  
19 February during 2011, accumulating 1,521.2 hours of operation over 420 MW. Peak  
20 operation of the BCC ST appears to have been in April 2011, with the ST producing  
21 457.6 MW, 9% in excess of design conditions. In total, the ST was operated in excess  
22 of 440 MW for over 1,160 hours in 2011.

1 **Q. HOW WAS THE BCC ST OPERATED IN 2012 UP THROUGH THE**  
2 **FEBRUARY 2012 OUTAGE?**

3 A. The ST was operated close to 450 MW in both January and February 2012,  
4 accumulating 77.9 hours of operation over 420 MW. Total operation in excess of ST  
5 design conditions since plant commercial operation in 2009 through February 2012,  
6 was almost 2,973 hours out of 21,734 hours of operation (from DEF Exhibit No. \_\_\_JS-  
7 1 (Docket No. 20180001-EI)). Over 13% of the operating hours in that initial period of  
8 operating the newly completed BCC plant were in excess of design conditions.

9

10 **Q. DID DEF INFORM MHPS IT INTENDED TO OPERATE THE BCC ST ON A**  
11 **REGULAR BASIS IN EXCESS OF 420 MW?**

12 A. In response to OPC Fourth Set of Interrogatories, Interrogatory 21, DEF states;  
13 “DEF did not correspond or discuss operating the steam turbine at 450 MW.” As of the  
14 filing of this testimony, DEF has not produced any documentation from MHPS that  
15 shows MHPS acknowledging or agreeing that the BCC ST could be operated in excess  
16 of 420 MW. In his 2018 testimony, DEF witness Jeffery Swartz includes Exhibit No.  
17 \_\_\_(JS-1) (Docket No. 20180001-E1) which contains a Table A, titled “Bartow L-0  
18 Events Summary” which breaks down the history of the BCC ST operation into five  
19 (5) periods. In the first column, labeled “Period 1” under the row titled “Key Notes  
20 from Period,” the following note is provided:

21 At the start of this period, MHPS approved 4X1 (unfired) operations at 392  
22 MW output, as well as 3X1 (duct fired) operation at 420 MW, supported by  
23 MHPS-provided heat balance documentation.

1                   This is further indication that MHPS was unaware of DEF's intent to operate—  
2                   or DEF's operation of—the BCC ST in excess of 420 MW. DEF has failed to provide  
3                   documentation as of the time of my testimony that MHPS provided DEF  
4                   documentation indicating that the ST could operate in excess of 420 MW.

5  
6                   **Q.   WHY DID DEF STATE IT FELT THERE WERE NO ISSUES WITH**  
7                   **OPERATION OF THE BCC ST IN EXCESS OF 420 MW?**

8                   A.           MHPS provided DEF with operating conditions that specified operating  
9                   parameters for the ST. These operating parameters included a variety of conditions,  
10                  including HP and IP ST section inlet pressure and temperature conditions and  
11                  condenser design conditions. After DEF performed a review in 2017-2018 of its initial  
12                  operation of the BCC ST, DEF was of the opinion that, if steam conditions to the ST  
13                  were within the HP, IP, condenser pressure, and temperature operating parameters,  
14                  output of the BCC ST could be increased until these parameters were reached. DEF has  
15                  provided no contemporaneous documentation from the period prior to the February  
16                  2012 outage of DEF's operating the newly installed BCC that MHPS concurred in  
17                  DEF's retrospective claim. The result of DEF's decision was that it raised the  
18                  horsepower output of the ST such that it was producing over 450 MW, which is 9%  
19                  higher than MHPS design conditions.

20  
21                  **Q.   WHAT HAPPENED IN FEBRUARY 2012 AT BCC?**

22                  A.           DEF scheduled a planned outage for valve work and inspection of the LP ST  
23                  blades. During the inspection of the L0 blades, damage was found on five of the L0

1 blades located on the generator end of the LP ST. The L0 blades are the last row of  
2 blades the steam passes through prior to entering the condenser and are the longest  
3 blades in the ST at 40”.

4

5 **Q. WERE THERE SUBSEQUENT BLADE FAILURES AFTER FEBRUARY**  
6 **2012?**

7 A. Yes, as shown in DEF’s 2018 Exhibit No. \_\_\_\_ (JS-1), there were subsequent  
8 blade failures, including failures of MHPS redesigned blades. In February 2017, BCC  
9 experienced an outage due to L0 blade failures, and DEF decided to install a “pressure  
10 plate” to replace the L0 blades until a solution was found to the blade failures. A  
11 pressure plate is a disk with engineered holes to reduce the steam energy, allowing it  
12 to decrease in pressure to condenser pressure. The pressure plate does not convert any  
13 of the steam force into turbine horsepower and results in a loss of turbine horsepower.  
14 This resulted in the BCC ST maximum output being limited to only 380 MW. This, in  
15 turn, is what caused a derate of the ST from 420MW to 380MW. This derate was a  
16 natural consequence of the cascading series of blade failures precipitated by DEF’s  
17 operation of the ST in Period 1.

18

19 **VI. EVALUATION OF BCC STEAM TURBINE BLADE FAILURES**

20 **Q. HOW MANY TIMES DID DEF DISCOVER PROBLEMS WITH THE BCC ST?**

21 A. DEF found damage to L0 blades on three other occasions after the initial blade  
22 damage was discovered in February 2012. As alluded to above, DEF separated the ST  
23 operating history into 6 periods. Period 1 starts with commercial operation and extends

1           until the problems were found during the February 2012 outage. Period 2 began after  
2           the February 2012 outage and extends until November 2014 when new L0 blades (Type  
3           2 blades) were installed. Period 3 begins at the end of the 2014 outage and lasts until  
4           April 2016 when problems were found with the Type 2 blades. Period 4 begins with  
5           the installation of the second redesigned L0 blades (Type 3 blades) in June 2016 and  
6           ends when blade failures were found in October 2016. Period 5 starts when DEF  
7           decided to reinstall the original design Type 1 blades in December 2016 and ends in  
8           January 2017 when the component called the burst diaphragm was damaged by parts  
9           from these L0 blades. Period 6 began in April 2017 after the L0 blades were replaced  
10          by a pressure plate and is expected to continue until the end of September of this year.

11

12   **Q.    WHAT ACTION DID DEF TAKE AFTER THE BLADE DAMAGE WAS**  
13   **DISCOVERED IN FEBRUARY 2012?**

14   A.           Upon finding the 2012 blade failures, DEF engaged MHPS and several other  
15           entities to determine the cause of the blade failures. MHPS conducted a Root Cause  
16           Analysis (“RCA”) of the failures. MHPS first stated in a report dated September 18,  
17           2013, that “Mitsubishi estimated the cause of the [blade] cracking was overloading the  
18           LP section based upon 450 MW which is over the design point of 420 MW.” In this  
19           report, MHPS estimates the ST was operated in excess of 420 MW for 2,600 hours,  
20           over 15% of the operating hours. This is consistent with, but still understates, the 2,973  
21           operating hours derived by totaling the hours in column 420 for Period 1 in Exhibit No.  
22           \_\_\_\_(RAP – 5).

1                    Since all the damaged blades in Period 1 were on the generator end of the ST,  
2                    the L0 blades were replaced only on that end of the ST with Type 1 blades. MHPS  
3                    informed DEF not to operate the ST above 420 MW and limited IP section exhaust  
4                    pressure to 118 psig. During Period 2, DEF only exceeded the 420 MW limit for 1.7  
5                    hours. Average maximum monthly load was only 396 MW during Period 2. The ST  
6                    was removed from service in September 2014 to install the Type 2 blades.

7

8    **Q.        WHAT WAS THE CONDITION OF THE L0 40” BLADES AT THE END OF**  
9                    **PERIOD 2?**

10    A.            The Type 1 L0 40” blades used during Period 2 did not experience any broken  
11                    snubbers or z-locks. According to DEF documents, no significant damage was found.

12

13    **Q.        BASED UPON THE VARIOUS DOCUMENTS PROVIDED BY DEF, WHAT**  
14                    **WAS THE CAUSE OF THE L0 40” BLADE FAILURES UP UNTIL THE END**  
15                    **OF PERIOD 2 (NOVEMBER 2014)?**

16    A.            The cause of the 40” L0 blade failures in the BCC LP ST during period 1 was  
17                    the result of DEF operating the unit in excess of the 420 MW design output. MHPS has  
18                    stated in multiple documents that operation of the ST, at horsepower levels sufficient  
19                    to generate greater than 420 MW resulted in overloading of the L0 blades. After over  
20                    2,600 (or up to 2,973) hours of operation in excess of 420 MW over a 63-month period,  
21                    the only type of failure that had manifested itself up to that point was the snubbers on  
22                    five blades of the generator end of the ST (See Exhibit No. \_\_\_\_ (JS-1). MHPS estimates  
23                    the loading on the L0 blade at BCC ranged from 15,000 lb/FT<sup>2</sup>-h to 17,000 lb/FT<sup>2</sup>-h

1 (Exhibit No. \_\_\_(RAP-6), at 7, 19, and 20). Notably, the Period 1 snubber failures in  
2 the L0 blades experienced at BCC had not been experienced at other MHPS plants  
3 equipped with 40" L0 blades (See statements by MHPS in Exhibit No. \_\_\_(RAP-7), at  
4 7 and Exhibit No. \_\_\_(RAP-8), at 8). Likewise, the range of operation and significantly  
5 higher loadings imparted on the ST by DEF operating the ST in excess of design  
6 conditions, was unique among the MHPS ST units. Operation of the BCC ST to  
7 produce an output appreciably in excess of 420 MW resulted in forces on the L0 blades  
8 that were 13% to 25% higher than the other MHPS units of similar design. Thus, it is  
9 obvious that DEF's operation of the BCC ST above the 420 MW design was a material  
10 cause of the failure of the L0 blades.

11

12 **Q. WHAT WOULD ST OPERATIONAL OUTCOME HAVE BEEN IF DEF**  
13 **OPERATED THE BCC ST AT OR BELOW THE ORIGINAL DESIGN**  
14 **CONDITIONS DURING PERIODS 1 & 2?**

15 A. Based upon the information provided in various documents and the RCA  
16 conducted by MHPS, DEF has not demonstrated that the original L0 blades would have  
17 experienced even minimal degradation over the design life of these blades if it had  
18 operated the BCC ST at or below the original design output of 420 MW. The Type 1  
19 blades lasted for a period of only about five years after being subjected to stresses  
20 significantly beyond original design. The impact of stress on steam turbine blades is a  
21 cumulative effect and when a blade as long as the L0 blades is subjected to much higher  
22 than design forces, the impact is not linear.

1 **VII. EVALUATION OF REPLACEMENT POWER COSTS ASSOCIATED WITH**  
2 **BCC GENERATION LOSSES**

3 **Q. HAS DEF DEMONSTRATED THAT ITS RATEPAYERS SHOULD BE**  
4 **RESPONSIBLE FOR THE REPLACEMENT POWER COSTS**  
5 **ASSOCIATED WITH OUTAGES AND REDUCED PRODUCTION FROM**  
6 **THE BCC PLANT AS A RESULT OF THE LP ST L0 BLADE FAILURES?**

7 A. No, DEF has failed to demonstrate that it should not be responsible for  
8 the costs resulting from its operation of the ST. As presented earlier in my  
9 testimony, the failures of the original L0 blades are the result of DEF operating  
10 the ST above the 420 MW design condition. All subsequent outages and derates  
11 since 2012 have their origin in the operation of the ST in excess of 420 MW. DEF  
12 has failed to demonstrate that had it operated the ST within original design  
13 conditions the original blades would not still be in operation. If the original L0  
14 blades had not failed due to DEF's operation of the BCC ST beyond the 420 MW  
15 design, DEF would not have installed the Type 2 and Type 3 blades, nor  
16 experienced the associated outages. In addition, if the original L0 blades had not  
17 failed due to DEF's operation during Period 1, the pressure plate would not be  
18 currently installed, and the ST would be capable of producing its designed output  
19 of 420 MW. DEF knew or should have known the designed generation capability  
20 of the ST was only 420 MW from the thermal analysis performed prior to  
21 operation and from the contract documents for the MHPS ST. These documents  
22 show the unit was designed for output of 420 MW. If DEF had discussed operation  
23 of the ST above 420 MW with MHPS prior to the initial operation at higher load,

1 the problems encountered with the ST at BCC likely would have been avoided.  
2 As of the filing of my testimony, DEF has not provided documentation that such  
3 discussion actually occurred.

4

5 **Q. HOW DOES THE REPLACEMENT OF THE L0 BLADES WITH THE**  
6 **PRESSURE PLATE IN THE BCC LOW PRESSURE TURBINE AFFECT**  
7 **THE ST OPERATION?**

8 A. The replacement of the ST L0 blades in the LP with the pressure plate  
9 results in a derate of the ST to 380 MW, according to DEF. This is a derate of 40  
10 MW from the 420 MW original design condition.

11

12 **Q. HOW DOES A DERATE OF THE BCC ST TO 380 MW AFFECT THE**  
13 **SUPPLY OF POWER TO DEF CUSTOMERS?**

14 A. The reduction in BCC capability to produce full output has caused an  
15 increase in power costs for DEF. Utilities schedule plant operation with the most  
16 economical plants dispatched first. If a plant is derated, another plant with higher  
17 power costs is used to replace the lost MWs, subjecting DEF's ratepayers to  
18 higher power costs.

19

20 **Q. HOW SHOULD THE COST OF REPLACEMENT POWER FOR THE**  
21 **MWH BCC IS UNABLE TO PRODUCE DUE TO THE ST BEING**  
22 **DERATED BY 40 MW BE CALCULATED?**

1 A. BCC is one of DEF's most efficient and lower-cost operating units. Once  
2 it is scheduled to produce power at full load, approximately 1,140 MW, any  
3 additional generation needed to meet DEF's load will be more costly. As load  
4 increases, so does the cost of generation up to the point the daily peak load occurs.  
5 Since BCC is unable to produce the full 1,140 MW, the highest cost power in  
6 every hour should be used to calculate replacement power costs. Thus, the  
7 replacement power costs for the 40 MW derate of the BCC ST would be the cost  
8 of DEF's highest 40 MW block of power supply. This is the correct method of  
9 replacement power cost calculation for this derate because, if the ST were able to  
10 produce the additional 40 MW, DEF would not be paying the highest cost 40MW  
11 block in that hour. In response to OPC Interrogatory 35, DEF provided the highest  
12 cost power for each hour during the period of April 1, 2017 to August 31, 2019.  
13 If DEF's highest hourly power cost was higher than the generation cost of BCC,  
14 then BCC should be operating at maximum output during that hour. Using the  
15 hourly BCC heat rate and daily natural gas prices provided by DEF in response to  
16 OPC Interrogatory 44, the hourly generation cost for BCC was calculated. If the  
17 hourly BCC generation cost was lower than the highest hourly power price for  
18 DEF, then it is assumed DEF would be running at full load. The replacement  
19 power cost is equal to the highest hourly price minus BCC's generation cost times  
20 40 MW.

21

22 **Q. HAS DEF PROVIDED AN ESTIMATE OF THE REPLACEMENT**  
23 **POWER COSTS FOR THE BCC OPERATIONAL PERIOD AFTER**

1           **INSTALLATION OF THE PRESSURE PLATE IN THE LP SECTION OF**  
2           **THE ST?**

3    A.           Yes, DEF provided in response to OPC Interrogatories 33 and 44, an  
4           estimate of the replacement power costs due to the installation of the pressure  
5           plate on BCC ST for the period April 10, 2017, through August 31, 2019. DEF's  
6           calculation of the replacement power costs include an estimate of the portion of  
7           the 40 MW derate that would have been generated if the L0 blades had been  
8           installed, for each hour of the period, considered to be the hourly replacement  
9           power. The estimated replacement power in DEF's calculation is not consistent  
10          with how plants are dispatched based upon power costs. For example, DEF's  
11          calculation shows ZERO replacement power on June 1, 2017, between the hours  
12          of 11:00–22:00 despite the replacement power costs averaging \$33.55/MWh,  
13          reaching a peak of \$46.62/MWh, and despite the cost for BCC to generate power  
14          during this time period being only \$22.68/MWh. The replacement power price  
15          over this period was more than \$10.00/MWh higher than the BCC operating costs;  
16          yet DEF did not include any replacement power costs for this period in its  
17          replacement power cost calculation. If the BCC ST had been available for full  
18          load during this period, the additional 40 MW would have reduced power costs  
19          by \$5,579. Review of the analysis by DEF finds many periods like this in which  
20          the replacement power cost was higher than BCC's cost of generation and that  
21          DEF did not include any replacement power costs due to the installation of the  
22          pressure plate on BCC ST, in the total replacement power cost calculation. As  
23          such, DEF's replacement power costs are not a realistic representation of the

1 replacement power costs DEF incurred as a result of the BCC ST 40 MW derate.  
2 DEF has clearly failed to demonstrate that its method of calculating derate related  
3 replacement power costs is reasonable.  
4

5 **Q. WHAT TIME PERIOD IS COVERED BY YOUR ANALYSIS OF**  
6 **REPLACEMENT POWER COSTS?**

7 A. My estimate of replacement power costs for BCC covers three time  
8 periods: 2017, including the 2017 outage of the BCC ST; 2018, including the  
9 outage to repair the LP casing cracks due to the operation of the ST with the  
10 pressure plate; and the 2019 forecasted replacement power costs for the lower ST  
11 output associated with operation of the ST with the pressure plate, up to the fall  
12 outage planned to begin September 28, 2019.  
13

14 **Q. HOW WERE THE REPLACEMENT POWER COSTS DETERMINED**  
15 **FOR THE BCC OUTAGE THAT OCCURRED BETWEEN FEBRUARY 9**  
16 **AND APRIL 8, 2017 (“BCC 2017 Outage”)?**

17 A. In Docket 20180001-EI, in Document No. 07025-2018, DEF witness Mr.  
18 Christopher A. Mendez provided testimony on page 5 for the replacement power  
19 costs incurred during the BCC 2017 Outage. Based upon his testimony, the  
20 replacement power costs were \$11.1 Million. I do not take issue with this number,  
21 nor have I run production cost modeling analyses to verify it.

1 Q. WHAT WERE THE REPLACEMENT POWER COSTS DUE TO BCC  
2 OPERATING WITH THE PRESSURE PLATE FOR THE REMAINDER  
3 OF 2017?

4 A. The replacement power costs for the BCC 40 MW derate in 2017 after  
5 installation of the pressure plate in the LP section of the ST was ~~\$2,005,536~~ <sup>\$1,675,561</sup>. This  
6 represents the costs for ~~162,040~~ <sup>150,400</sup> MWh of replacement generation. The calculation  
7 of these power costs are provided in Exhibit No. \_\_\_(RAP-9), lines 1-9.

Court  
Reporter:  
DK

8  
9 Q. WHAT WERE THE REPLACEMENT POWER COSTS DUE TO BCC  
10 OPERATING WITH THE PRESSURE PLATE FOR 2018?

11 A. The replacement power costs for the BCC 40 MW derate in 2018 were  
12 ~~\$2,545,049~~ <sup>\$2,215,648</sup>. This represents the costs for ~~213,280~~ <sup>199,680</sup> MWh of replacement  
13 generation. The calculation of these power costs are provided in Exhibit No.  
14 \_\_\_(RAP-9), lines 10-21.

Court  
Reporter:  
DK

15  
16 Q. WHAT WERE THE REPLACEMENT POWER COSTS DUE TO BCC  
17 OPERATING WITH THE PRESSURE PLATE FOR 2019, THROUGH  
18 AUGUST 31?

19 A. The replacement power costs for the BCC 40 MW derate in 2019 was  
20 ~~\$1,189,552~~ <sup>\$1,125,573</sup>. This represents the costs for ~~128,480~~ <sup>125,800</sup> MWh of replacement  
21 generation. The calculation of these power costs are provided in Exhibit No.  
22 \_\_\_(RAP-9), lines 22-29.

Court  
Reporter:  
DK

1 Q. WHAT IS THE TOTAL REPLACEMENT POWER COSTS SINCE DEF  
2 REPLACED THE LP ST L0 BLADES WITH THE PRESSURE PLATE?

3 A. The total replacement power costs for the 2017 outage and the BCC ST  
4 derate for years 2017, 2018 and 2019 is ~~\$16.84~~ **\$16,116,781** million.

**Court  
Reporter:  
DK**

5  
6 Q. DOES THAT CONCLUDE YOUR TESTIMONY?

7 A. Yes, it does. However, I reserve the right to file supplemental testimony  
8 to the extent any material new information is subsequently filed that was  
9 requested and was available, but was not provided prior to my testimony filing.

1 THE COURT: And I guess, did we need to move a  
2 revised Exhibit 9?

3 MR. DAVID: Yes.

4 MR. REHWINKEL: Your Honor, staff has  
5 requested, and I think correctly so, that we  
6 identify an exhibit, and we would just give it the  
7 next exhibit number, and this would be his revised  
8 RAP-9, which would be whatever the next number is.

9 THE COURT: 118.

10 MS. BROWNLESS: 117.

11 THE COURT: Okay, 117. We will mark it as  
12 117, and without objection show it admitted.

13 (Whereupon, Exhibit No. 117 was marked for  
14 identification and received into evidence.)

15 MR. DAVID: And, Your Honor, just to be clear,  
16 when I moved the testimony in, that that includes  
17 the updates he made.

18 THE COURT: He has got a notice on the record.  
19 Yeah, we got that.

20 And how do we handle, Duke leads it off?

21 MR. BERNIER: Yep.

22 THE COURT: Okay.

23 EXAMINATION

24 BY MR. BERNIER:

25 Q Good morning, Mr. Polich.

1           A     Good morning.

2           **Q     Good to see you again. Just a couple of**  
3 **preliminary questions.**

4                   **You do not have any experience designing steam**  
5 **turbines, is that correct?**

6           A     I have experience -- I -- let me rephrase  
7 this. My experience with design of steam turbines  
8 involves the thermal cycles and how they match up with  
9 the existing steam turbine that I was provided.

10          **Q     Thank you.**

11                   **But when it comes to physically designing the**  
12 **steam turbine, you don't have any experience doing that?**

13          A     Not direct.

14          **Q     Thank you.**

15                   **Do you have any experience designing -- you do**  
16 **not have any experience designing steam turbine blades,**  
17 **is that correct?**

18          A     That is correct.

19          **Q     Okay. You do not have any direct operational**  
20 **experience with steam turbines, is that correct?**

21          A     Define what you mean by direct.

22          **Q     Have you ever -- you do not have any**  
23 **experience sitting at the control panel operating the**  
24 **steam turbine?**

25          A     I have supervised those who are at the control

1 panel.

2 **Q But any experience operating the steam**  
3 **turbine?**

4 A No.

5 **Q You don't have any specific operational or**  
6 **design experience with a Mitsubishi steam turbine in**  
7 **particular, is that correct?**

8 A I have never operated a Mitsubishi steam  
9 turbine.

10 **Q You have never provided expert testimony**  
11 **regarding the design of steam turbines, is that correct?**

12 A I have not provided expert testimony on the  
13 design of steam turbines.

14 **Q And you have never provided expert testimony**  
15 **regarding the operation of steam turbines, is that**  
16 **correct?**

17 A That is correct.

18 **Q I believe you testified earlier during your**  
19 **summary that you reviewed documents and testimony in**  
20 **forming your opinions?**

21 A Yes, I did.

22 **Q Did you physically examine any of the damaged**  
23 **blades?**

24 A No, I did not.

25 **Q And you did not speak or correspond with**

1 anyone from Mitsubishi as part of your testimony for  
2 preparation, is that correct?

3 A No, I did not.

4 Q And you would agree that the steam turbines  
5 should be operated within the operating parameters  
6 provided by the unit's manufacturer, is that correct?

7 A All the operating parameters, yes.

8 Q And you also agree that the megawatt output of  
9 the steam turbine is largely dependent on how you  
10 operate the unit within those parameters?

11 A I do not.

12 Q You do not?

13 A I do not. The megawatt output is an operating  
14 parameter.

15 Q Do you remember when I took your deposition in  
16 October?

17 A Yes, I do.

18 Q And when I asked you in October, the question  
19 was: My understanding -- let me ask you what your  
20 understanding of the difference between the expected  
21 output and the operating limits?

22 And you said: There actually is not a direct  
23 correlation. The operating limits are dependent upon  
24 various conditions of operation, generally defined a set  
25 of operating parameters providing you an envelope in

1     **which you are to operate the steam turbine within, and**  
2     **for the most part, the megawatts is dependent upon how**  
3     **you operate within those limits.**

4           A     And I will still stand by that testimony that  
5     I still contend that the megawatt output has limits  
6     because it is a critical factor in defining how much  
7     horsepower a steam turbine is producing and what the  
8     stressers are within that steam turbine. And so  
9     megawatt output is a critical factor in operation of the  
10    steam turbine.

11           **Q     Based on information you reviewed, did Duke**  
12    **Energy operate the steam turbine within the pressures**  
13    **and temperatures provided by the OEM?**

14           A     Based on the data that I have reviewed, yes.

15           **Q     And am I correct that your opinion regarding**  
16    **DEF's operational prudence is limited to operation**  
17    **during what is referred to as Period 1 in Mr. Swartz's**  
18    **exhibit?**

19           A     I reviewed the operation through all the  
20    periods.

21           **Q     That's correct. My question is, am I correct**  
22    **that your contention in your testimony is that DEF was**  
23    **imprudent in its operation in Period 1?**

24           A     Correct.

25           **Q     Okay. And you agree that DEF was prudent when**

1 **operating the steam turbine in Period 2, correct?**

2 A The pause is because I am recollecting some of  
3 the conditions during Period 2. Let me look at  
4 something here.

5 **Q Sure.**

6 A Based upon the information provided by Duke in  
7 which -- with the exception of September of 2013 in  
8 which there was actually some testing being done, the  
9 operation of that unit at all times was below the  
10 420-megawatt limit, so I would say yes.

11 **Q And notwithstanding that DEF prudently**  
12 **operated the machine during Period 2, at the conclusion**  
13 **of Period 2, DEF still found damage to the blades; is**  
14 **that right?**

15 A The damage was described as minor, but, yes,  
16 there was some minor.

17 **Q And you agree that DEF was prudent when**  
18 **operating the steam turbine in Period 3, correct?**

19 A To the best of my knowledge, yes.

20 **Q And notwithstanding that prudent operation**  
21 **during Period 3, at the conclusion of Period 3, DEF**  
22 **still found damage to those blades; is that correct?**

23 A Those were a different design blade, and so  
24 they are not correlated to Periods 1 and 2.

25 **Q Thank you.**

1                   At the end of Period 3, was there damage to  
2 **the blades?**

3           A       Yes, there was.

4           Q       Okay. And those blades were also supplied by  
5 **Mitsubishi, is that correct?**

6           A       Yes.

7           Q       And you agree that DEF was prudent in  
8 **operating the steam turbine in Period 4, is that**  
9 **correct?**

10          A       Yes.

11          Q       And notwithstanding that prudent operation, at  
12 **the end -- at the conclusion of Period 4, DEF still**  
13 **found damage; is that correct?**

14          A       That's true.

15          Q       And you agree that DEF was prudent when  
16 **operating the steam turbine in Period 5, is that**  
17 **correct?**

18          A       Period 5 is an anomaly that I am not certain I  
19 can agree with.

20          Q       Do you remember when I deposed you in October,  
21 **sir?**

22          A       Yeah.

23          Q       Okay. And I asked you: Was Duke prudent, in  
24 **your opinion, prudent in its operation of the unit in**  
25 **Period 5? And your answer was: Yes.**

1 A Yes.

2 MR. DAVID: Your Honor, if he would show the  
3 witness the deposition testimony, I think it might  
4 help.

5 THE COURT: Yeah, it might be helpful.

6 MR. BERNIER: I will have to give you my copy,  
7 but I will show it to you real quick.

8 May I approach, Your Honor?

9 THE COURT: Sure.

10 MR. BERNIER: I should have asked first.

11 THE COURT: That's fine. You know the answer  
12 is yes.

13 BY MR. BERNIER:

14 Q Right there.

15 A Thank you.

16 Q So would you agree with me that that was your  
17 response?

18 A If you notice in my deposition, there were  
19 several caveats in regards to that issue. I mentioned  
20 the fact that the correlation between Period 1 and  
21 Period 5 do not make sense. And as I mentioned in my  
22 opening, there is no -- the fact that they failed, those  
23 blades failed so quickly in Period 5, indicates there  
24 were other dynamics happening, or that those blades in  
25 Period 5 were not identical to the ones in Period 1.

1           When you get only four percent or less of the  
2 hours of the same, quote/unquote, design set of blades  
3 as you did in the first period, then it is not a direct  
4 correlation. And the reason why I am not certain as to  
5 whether Duke prudently followed everything is I don't  
6 know all the dynamics that were going on inside of the  
7 condenser at the time, and I don't know if there were  
8 any conditions that might have happened. And, yes, this  
9 is in hindsight.

10           **Q     And just to circle back on that, you are**  
11 **speculating that there were other conditions in there**  
12 **that you are not aware of but you don't know that for**  
13 **fact?**

14           A     I agree.

15           **Q     Okay. And just to make sure that I understood**  
16 **your answer correctly, you agree that the operation of**  
17 **Period 5 was prudent?**

18           A     I agree that the inlet pressure conditions to  
19 the IP, HP and LP, as well as the megawatt limits were  
20 maintained by Duke, and that they did their best effort  
21 as I could tell of staying out of the avoidance zone  
22 mentioned by Mitsubishi.

23           **Q     I am going to just ask that one more time**  
24 **another way.**

25                   **You don't have any evidence that Duke operated**

1 the unit imprudently in Period 5?

2 A I will agree with that.

3 Q Okay. Thank you.

4 So from the beginning of Period 2 through the  
5 end of Period 5, which spans approximately April of 2012  
6 to February of 2017, approximately five years, you would  
7 agree that the steam turbine was operated prudently,  
8 correct?

9 A I am sorry, could you repeat that question  
10 again?

11 Q I would be happy to.

12 So from the beginning of Period 2 through the  
13 end of Period 5, which spanned approximately five years,  
14 you would agree that the steam turbine was operated  
15 prudently, correct?

16 A I would agree that it wasn't operated  
17 imprudently.

18 Q Fair enough. Thank you.

19 Now, if I understand your testimony correctly,  
20 your contention is that the blade damage discovered in  
21 Period 1 was caused by operating the steam turbine in a  
22 manner that produced over 420 megawatts; is that  
23 correct?

24 A That is correct.

25 Q And you would agree with me that during Period

1 1, the steam turbine was operated both above and below  
2 420 megawatts at various times?

3 A Yes.

4 Q And I believe on your Exhibit RAP-5, and  
5 Mr. Swartz testified to this yesterday, that it appears  
6 that it was roughly half the time above 420 and roughly  
7 half the time below 420; without doing the math, does  
8 that sound about right?

9 A That's close enough.

10 Q Okay. So using your definition that operation  
11 over 420 was imprudent, and because the steam turbine  
12 was operated below 420 megawatts in Period 1 at some  
13 points, you have to agree that at some points during  
14 Period 1, using your definition, the steam turbine was  
15 operated prudently?

16 A Yes.

17 Q Okay. And you cannot identify when the Period  
18 1 blades were damaged, can you?

19 A I cannot identify the exact instance in which  
20 they failed, and based on Mr. Swartz's testimony, he was  
21 not able to in Period 1 also.

22 The issue here, though, is the types of  
23 failures we are talking about more than likely were  
24 cumulative based upon the fracture pictures I saw. Even  
25 though I did not inspect the blades, there were plenty

1 of pictures and evidence in it, and my contention is  
2 that when they failed was immaterial.

3 **Q But you would agree with me that the Period 1**  
4 **blades could have been damaged when the unit was being**  
5 **operated below 420 megawatts, correct?**

6 A There is always that potential.

7 **Q So you would agree with me that the Period 1**  
8 **blades could have been damaged during prudent operation,**  
9 **correct?**

10 A Yes.

11 **Q But we do know that the damage in the later**  
12 **periods occurred when the steam turbine was being**  
13 **operated prudently, correct?**

14 A The damage did occur when the -- when it was  
15 operated within the operating parameters.

16 **Q And have you seen any evidence that there was**  
17 **any damage to any steam turbine component other than the**  
18 **L0 blades?**

19 A Other than -- other than, you know, subsequent  
20 damage associated with parts moving around, no.

21 **Q I am not sure I understand.**

22 A Well, for example, in Period 5, when the  
23 failure occurred, it threw the part out through the  
24 steam turbine. So, yes, there was something else that  
25 was damaged in the process.

1           **Q**     Fair enough. Okay. Just a couple others real  
2     **quickly.**

3                     **You indicated that Bartow was Progress**  
4     **Energy's first combined cycle?**

5           **A**     I believe it was.

6           **Q**     But would you agree with me if I told you that  
7     **the Hines power blocks were commissioned prior to**  
8     **Bartow?**

9           **A**     I was not aware of that.

10          **Q**     And does the steam turbine itself produce  
11     **megawatts?**

12          **A**     No.

13          **Q**     It's the generator that produces --

14          **A**     The generator does produce the megawatts.

15          **Q**     Thank you.

16                     **And in general, are there factors beyond the**  
17     **operation of the steam turbine that impact the megawatt**  
18     **outputs of the generator?**

19          **A**     One of the key ones that was discussed  
20     yesterday in Mr. Swartz's testimony, which is the issue  
21     of power factor, he brings up a very interesting point,  
22     although I think it's a red herring in this case, and  
23     that is because power factor is a very interesting  
24     animal in a power plant.

25                     You have four -- you have five different

1 generators on this power plant, each of which is capable  
2 of producing a different power factor, and you have the  
3 ability to adjust power factor based upon what's going  
4 on. There is also dynamics associated with the  
5 generator output which determines the power factor the  
6 generator typically is producing.

7 Now, Mr. Swartz yesterday brought up power  
8 factor which is a rather interesting issue, because if  
9 Duke is trying to raise this unit's output to  
10 450 megawatts, if you were to adjust that to the unity  
11 power factor that he discussed yesterday, that unit  
12 could be producing 500 megawatts, which exceeds the  
13 generator capability.

14 So I -- and if you look at all the  
15 documentation that's provided in this case, that power  
16 factor was never introduced. The 420 and 450 megawatts  
17 are the only numbers that are discussed in this case,  
18 and I think power factor is something that has not been  
19 factored into any of the evidence, the RCA or anything  
20 else.

21 **Q You would agree with me that power factor was**  
22 **included in those documents that were discussed**  
23 **yesterday?**

24 A Only in terms that they were specified as .95  
25 or .90.

1           **Q     And are there other variables beyond power**  
2 **factor that impact generator output?**

3           A     The efficiency of the steam turbine, of  
4 course, is always one. There is -- you know, it's  
5 ancillary. The numbers that we talk about,  
6 420 megawatts, is a net output. So to the extent that  
7 ancillary loads that are associated with that steam  
8 turbine can affect that 420, quote/unquote, but, you  
9 know, in transferring the horsepower from that steam  
10 turbine to the generator, there aren't many aspects that  
11 can change that number.

12           MR. BERNIER: If I could have just one minute.

13           THE COURT: Sure.

14           MR. BERNIER: Could we have five minutes?

15           THE COURT: Sure. Absolutely.

16           (Brief recess.)

17           THE COURT: Okay. Back on the record.

18           MR. BERNIER: Thank you for that break, Your  
19 Honor. Just a couple more.

20 BY MR. BERNIER:

21           **Q     Mr. Polich, you would agree with me that**  
22 **Mitsubishi was aware that Duke planned on operating the**  
23 **steam turbine in a 4-on-1 configuration, correct?**

24           A     Yes.

25           **Q     Do you know that DEF didn't contact Mitsubishi**

1     **about operating the unit over 420 megawatts in Period 1?**

2           A     There is no evidence that they asked  
3     Mitsubishi to operate over 420.

4           **Q     But you don't know whether or not it did occur**  
5     **or not?**

6           A     No, I don't.

7           **Q     And if I understand correctly, your contention**  
8     **is that the blade damage discovered in the spring of**  
9     **2017, after Period 5, was originated or caused by the**  
10    **operation in Period 1, was that correct?**

11          A     No.

12          **Q     No. I am not sure I understand.**

13          A     Repeat the question one more time.

14          **Q     Sure. Am I correct that your contention is**  
15    **that the damage that occurred in the spring of 2017,**  
16    **after Period 5, was caused by Duke Energy's operation of**  
17    **the unit above 420 megawatts in Period 1?**

18          A     No.

19                MR. BERNIER: Okay. We have nothing further.

20                Thank you.

21                THE COURT: Okay. Who's next? Okay.

22                MS. PUTNAL: No questions from FIPUG.

23                THE COURT: Nothing?

24                MS. PUTNAL: No questions from FIPUG.

25                THE COURT: Well, I guess redirect then.

1 MS. BROWNLESS: Excuse me, we have two  
2 questions.

3 THE COURT: Oh, I am sorry. I am sorry.

4 MS. BROWNLESS: Thank you.

5 EXAMINATION

6 BY MS. BROWNLESS:

7 Q Your Exhibit No. 5 in your testimony shows  
8 operating data for the Bartow unit from June 2009 until  
9 August of 2019, is that correct?

10 A Yes.

11 Q And you used this data to calculate the derate  
12 replacement power cost that you are seeking to recover,  
13 as found on your exhibit RAP-9, right?

14 A No.

15 Q You didn't use this data as the basis to  
16 develop the replacement cost?

17 A No. The data in RAP-5 is strictly associated  
18 with operation greater than 420 megawatts. Duke  
19 provided another set of documents that showed what the  
20 operations were on an hourly basis during the time  
21 periods in question.

22 Q And that's what you used?

23 A And that's what I used for calculating  
24 replacement power.

25 Q Is it your testimony that ratepayers should be

1       **compensated for megawatts that were not generated due to**  
2       **DEF's operation of the steam turbine under**  
3       **420 megawatts?**

4           A       Yes.

5           **Q       And should DEF also receive credit for the**  
6       **megawatts it produced over 420 megawatts in Periods 1**  
7       **and 2?**

8           A       No, because that wasn't subject of the  
9       proceeding, if I am correct.

10          **Q       Well, I guess what I am trying to ask is you**  
11       **believe they should be -- they should pay for megawatts**  
12       **they did not produce, but isn't it true that customers**  
13       **also got the benefit of megawatts in excess of 420 in**  
14       **Period 1?**

15          A       My testimony is dealing with periods after  
16       2016, and so Periods 1 and 2 would be prior to that.

17          **Q       So you don't think it would be appropriate to**  
18       **use the data in RAP-5 to figure out how many megawatt**  
19       **hours were produced in excess of 420 in Periods 1 and 2?**

20          A       Okay, to answer that question appropriately we  
21       would have to get into compensation and payments  
22       associated with power cost recovery cases. To the  
23       extent that power cost recovery cases typically are  
24       dollar for dollar what the utility spends is what the  
25       customer pays for.

1           Your supposition is that there was net benefit  
2   that Duke was not compensated for as a result of that.  
3   If we were to follow that line of questioning to its  
4   conclusion, you would be espousing that because the  
5   operation above 420 potentially reduced replacement --  
6   or reduced the power cost that customers were paying for  
7   and Duke should be compensated for that is actually  
8   contrary to the regulatory compact between utilities and  
9   their customers.

10           And in rate-making and rate proceedings,  
11   utilities normally don't get a profit, which that would  
12   be, for replace -- for power cost. But if utilities  
13   imprudently incur power costs, they will be docked --  
14   they can be docked in fuel cost recovery proceedings.

15           **Q    So if I understand what you are saying, the**  
16   **standard is 420. If they do less than 420, they are**  
17   **operating imprudently, and therefore should -- customers**  
18   **should be compensated for that, and if they are**  
19   **operating above 420, you are not saying that customers**  
20   **didn't benefit from those megawatts, are you?**

21           A    I didn't say that, no. Customers did -- I  
22   mean, customers -- to the extent -- and truth of the  
23   matter is I -- you know, without having the actual data,  
24   all right, my guess, based on the fact that Duke did  
25   operate the unit more than 420 was that their cost

1 occurs associated with the stacking of their various  
2 generation units indicated that it was more prudent to  
3 operate Bartow above 420 to reduce the overall power  
4 cost to customers. And so that was a prudent decision  
5 from that perspective, absent the fact that they were  
6 violating the operating parameters of the unit, all  
7 right.

8 Now, that is factored already in your power  
9 supply cost recovery proceedings, all right.

10 The second thing is that what I am talking  
11 about, and it's in my testimony, is associated with the  
12 installation of a pressure plate and associated derate  
13 as a result of that. And my contention is, is that the  
14 reason the pressure plate was put in place was due to  
15 improper operation above 420 megawatts in Periods 1.

16 **Q Okay.**

17 **A** And so it's not the same animal from my  
18 perspective.

19 **Q I understand.**

20 **And I just want to ask one question. You have**  
21 **indicated that if Duke had called Mitsubishi and said we**  
22 **are going to operate it at this higher level, and**  
23 **Mitsubishi had given them permission to do that, that we**  
24 **all wouldn't be here today; is that correct?**

25 **A** And that permission would -- should have been

1 in writing.

2 **Q Okay.**

3 A It should have been something that allowed  
4 Duke to go back to Mitsubishi from a warranty  
5 perspective, so that, you know, okay, we asked you. We  
6 gave you the parameters we were going to operate under,  
7 and you came back and said that's okay, then the onus is  
8 on Mitsubishi.

9 **Q And if they simply asked Mitsubishi and got  
10 permission but never got written permission, would that  
11 change your opinion?**

12 A No, because we are dealing with regulatory  
13 proceedings here, and the additional step of getting it  
14 in writing is minimal. It doesn't take any effort to do  
15 that. And so the prudent thing to do, especially when  
16 you are dealing with a regulatory or a contractual issue  
17 is you get it in writing. Any attorney that I have ever  
18 been associated with would tell you that.

19 **Q All right. Thank you so much. That's all we  
20 have.**

21 A Thank you.

22 THE COURT: Ms. Putnal, I apologize, I was --  
23 I was promoting you to the Commission. That's why  
24 I thought we hadn't met. I just realized she's in  
25 Mr. Moyle's chair.

1 MS. PUTNAL: Thank you.

2 THE COURT: I think we are to redirect.

3 MR. REHWINKEL: Yes. Thank you, Your Honor.

4 Just a few questions.

5 EXAMINATION

6 BY MR. REHWINKEL:

7 Q Mr. Polich, can you tell me, I think you were  
8 asked by Mr. Bernier if you had contacted Mitsubishi in  
9 any part of this process; do you recall that?

10 A Yes.

11 Q In your opinion, in your expert -- in your  
12 experience in the business, would it have been  
13 appropriate for you to have contacted Mitsubishi in this  
14 case?

15 A No. And, in fact, you know, if I had, I think  
16 there would have been some issues by Duke associated  
17 with my doing that.

18 And in addition, I doubt Mitsubishi would talk  
19 to me anyways because of the fact that a lot of the  
20 information I would have been seeking is probably under  
21 confidentiality and would not be -- so it would have  
22 been useless for me to contact Mitsubishi.

23 Q Mr. Bernier also asked you -- do you recall  
24 him asking you about whether damage was found in Period  
25 2?

1           A     Yes.

2           **Q     In the course of your discovery in this case,**  
3 **did you see any evidence that Duke believed there was**  
4 **either no damage or damage that was pretty typical and**  
5 **the type that could have been smoothed out during the --**  
6 **during a planned outage?**

7           A     Well, in fact, if you go to Duke's RCA Table  
8 A, and you look at what was found in Period 2 and you  
9 come down to a line that says broken snubbers, there is  
10 zero on the turbine end. There was zero on the governor  
11 end. You look at the broken Z-lock, zero on the turbine  
12 end zero on the governor end. Moderate amount of  
13 surface fretting and galling observed, which is normal.

14                     Duke operated the machine within the  
15 parameters of -- and below 420 megawatts with the  
16 exception of the one test that they performed during  
17 that time period, and this was 28 months of operation,  
18 21,000 hours, and basically no damage.

19           **Q     Do you recall being asked about damage in**  
20 **Periods 2 through 5?**

21           A     Yes.

22           **Q     Is it your opinion that the blades throughout**  
23 **Periods 2 -- well, throughout all five periods were**  
24 **similar enough for you to make a direct comparison about**  
25 **prudent operation and impact on the blades?**

1           A       No. I mean, when you got to Period 3, Duke  
2 was -- you know, not Duke, but Mitsubishi installed the  
3 Type 3 blades, which were a different design. Some of  
4 the interesting things that they did to the blades in  
5 terms of surfaces on the snubbers and the Z-locks I  
6 believe contributed to the problems instead of, you  
7 know -- instead of resolving them.

8                   And so going back to the comparison between  
9 those periods and Period 1, I don't think they are  
10 correlatable, and especially when you get to Period 5;  
11 because again, you got to come back to why did the  
12 Period 5 blades which were, quote/unquote, identical to  
13 the Period 1 blades fail in only four percent of the  
14 operating hours, and include throwing a piece through  
15 the steam turbine casing? Actually, I think it was the  
16 pressure disc, but it's -- it's -- from an engineering  
17 perspective, it doesn't add up, and so I don't think  
18 there is a correlation.

19           **Q       Do you recall Mr. Bernier asking you whether**  
20 **you had any knowledge if Duke contacted Mitsubishi**  
21 **during Period 1?**

22           A       Yes.

23           **Q       Okay. In the process of doing discovery in**  
24 **the proceeding, did you ever hear Mr. Swartz state that,**  
25 **for all I know, there may have been no discussion with**

1 **Mitsubishi relative to that period?**

2 A I recall that in a deposition.

3 **Q Do you recall Mr. Swartz saying, I am not sure**  
4 **how much interaction was going on with Mitsubishi with**  
5 **respect to that period?**

6 A I recall.

7 **Q And finally, you were asked a question by**  
8 **staff counsel about going back and looking at 2009 and**  
9 **the value that the customers might have gotten out of**  
10 **operating above 420 --**

11 A Yes.

12 **Q -- do you recall that?**

13 **Are you also generally aware that after**  
14 **October 2nd of 2009, Duke had damage to the Crystal**  
15 **River 3 nuclear plant --**

16 MR. BERNIER: I object, Your Honor. This is  
17 pretty irrelevant.

18 THE COURT: Let him finish the question.

19 BY MR. REHWINKEL:

20 **Q And was -- without 1,000 megawatts or so of**  
21 **base-load generation for the next three years?**

22 MR. BERNIER: Same objection, Your Honor.

23 MR. HERNANDEZ: It's also beyond the scope  
24 of --

25 MR. REHWINKEL: If I could be heard, Your

1 Honor.

2 THE COURT: Sure.

3 MR. REHWINKEL: There was -- I could ask a  
4 question in front of that one so you could  
5 understand, but the assertion -- the question by  
6 the staff, which I think was an informational  
7 question, was to know whether there was a benefit  
8 that customers were unduly receiving from this  
9 excess generation. But to complete the picture,  
10 the Court needs to understand whether there was a  
11 replacement power need that Duke might have been  
12 filling by running the unit above 420, and thus  
13 that would have all been taken care of in the fuel  
14 adjustment process and the ensuing proceedings.

15 MR. BERNIER: I apologize, Your Honor, that is  
16 not at all relevant. I think she was asking  
17 whether or not customers received the benefit of  
18 that added generation, and whether or not there was  
19 an outage at another plant at another time is  
20 completely irrelevant. That's not what we are here  
21 talking about today.

22 MR. REHWINKEL: I can withdraw the question.

23 THE COURT: I am going to sustain. I think we  
24 are kind of getting into the weeds here.

25 MR. REHWINKEL: All right. That's all I have.

1 Mr. David may have a question.

2 FURTHER EXAMINATION

3 BY MR. DAVID:

4 Q Mr. Polich, in your experience -- how long --  
5 once again, how long have you been an engineer?

6 A Since 1978.

7 Q Okay. In your experience, do prudent  
8 engineers base analyses on oral information?

9 A My hesitancy is because we will conduct  
10 preliminary analyses based upon oral information. But  
11 in the case, especially when you are looking at design  
12 of a power plant or something like that, you are going  
13 to want confirmation especially if that information is  
14 being provided by an OEM, because your client is going  
15 to expect you to have that documentation and information  
16 because utilities are regulated entities. Their  
17 operations are always under public scrutiny and  
18 questioning. And so an entity such as Duke would expect  
19 their -- their owner -- their engineer on a project to  
20 have that documentation because if there is questions  
21 some point in the future, they are going to want to be  
22 able to provide the proper evidence if needed.

23 Q Thank you.

24 And to staff's line of questions, in your  
25 calculation of damages that was in, I believe it's now

1    **been identified as Exhibit 117, did you only take into**  
2    **account when power was needed, or did you just take into**  
3    **account the fact that they weren't producing 420, so**  
4    **you -- so they -- you docked them for that?**

5           A     I did, yes. I did look at only when that  
6    power would have been needed. There are definitely  
7    hours in there in which, based upon the information  
8    provided by Duke, I could identify those hours in which  
9    the additional megawatts would not be necessary, and I  
10   excluded those hours from my calculations.

11           Q     **Okay. Last one.**

12                   **In your opinion, did the operation of the**  
13    **steam turbine in Period 1, the manner of operation of**  
14    **the steam turbine in Period 1 affect the condition**  
15    **performance of the steam turbine after that period,**  
16    **including Periods 3 and beyond?**

17           A     Interesting question from the perspective of  
18    how operation of a steam turbine in earlier periods  
19    affects opera-- affects the way that steam turbine  
20    performs in later periods.

21                   Clearly, you know, by the time you get to  
22    Period 5, this unit has been in operation for, you know,  
23    eight some odd years, and there will be some wear on  
24    components within that turbine. Duke has stated that  
25    Mitsubishi did a very thorough analysis of those

1 components and didn't find anything out of the ordinary.  
2 It doesn't mean that there wasn't some wear and tear  
3 that occurred. And that wear and tear can affect how  
4 the performance of a set of blades put in in subsequent  
5 periods. The question is how much that can affect it.

6 MR. DAVID: No more.

7 THE COURT: Okay. Thank you, Mr. Polich.

8 THE WITNESS: Thank you.

9 (Witness excused.)

10 MR. DAVID: And, Your Honor, at this point, I  
11 would like to move all of Mr. -- the exhibits to  
12 Mr. Polich's testimony in there, except I will  
13 withdraw what's been identified as -- on the CEL as  
14 Exhibit 76, since it was the incorrect one, and  
15 offer exhibits 68 through 75 and Exhibit 117.

16 THE COURT: I think 117 we've already  
17 admitted.

18 MR. DAVID: Okay. I just wanted to make sure  
19 we are clear.

20 THE COURT: Without objection, we will show 68  
21 through 75.

22 MR. DAVID: And withdraw 76, thank you.

23 THE COURT: Okay. 76 is out.

24 (Whereupon, Exhibit Nos. 68 - 75 were received  
25 into evidence.)

1 THE COURT: According to my script, we are up  
2 to the rebuttal.

3 MR. BERNIER: Yes, sir. Duke Energy would  
4 recall Mr. Swartz.

5 THE COURT: Mr. Swartz, I will just remind you  
6 you are still under oath.

7 THE WITNESS: Yes, sir.

8 THE COURT: I am not going to swear you in  
9 again. I think it's like the flu, the vaccine only  
10 last a couple of days.

11 Whereupon,

12 JEFF SWARTZ

13 was recalled as a witness, having been previously duly  
14 sworn to speak the truth, the whole truth, and nothing  
15 but the truth, was examined and testified as follows:

16 EXAMINATION

17 BY MR. BERNIER:

18 Q Good morning again, Mr. Swartz.

19 A Good morning.

20 Q I believe the judge has reminded you that you  
21 remain under oath, is that correct?

22 A Yes, that's correct.

23 Q Okay. Good deal.

24 On or about September 26th of 2019, did you  
25 cause to be filed rebuttal testimony in the 2009 fuel

1 docket before the Florida Public Service Commission?

2 A Yes.

3 Q And do you have of a copy of that testimony  
4 with you today?

5 A I do.

6 Q And I believe your testimony -- your rebuttal  
7 testimony included exhibits JS-2, 3 and 4, is that  
8 correct?

9 A Yes, that's correct.

10 Q And you have those with you today?

11 A I do.

12 Q Do you have any changes to make to your  
13 testimony?

14 A No changes.

15 Q If I was to ask you the same questions here  
16 today, would your answers be the same?

17 A Yes, they would.

18 Q Okay.

19 MR. BERNIER: Judge, at this time, we would  
20 ask that his rebuttal testimony be read -- entered  
21 into the record as though read.

22 THE COURT: As if read. Hearing no objection,  
23 we will show that done.

24 (Whereupon, prefiled testimony was inserted.)

25

1                   BEFORE THE FLORIDA PUBLIC SERVICE COMMISSION  
2                                   REBUTTAL TESTIMONY OF  
3   JEFFREY SWARTZ  
4   ON BEHALF OF  
5                                   DUKE ENERGY FLORIDA  
6                                   DOCKET NO. 20190001-EI  
7   September 26, 2019

8

9   **Q.    By whom are you employed and in what capacity?**

10  A.    I am employed by Duke Energy Florida (“DEF” or the “Company”) as Vice President  
11        – Generation.

12

13 **Q.    Have you previously filed testimony in this docket?**

14  A.    Yes, I filed testimony related to the February 2017 outage of the Bartow Combined  
15        Cycle (“Bartow CC”) Steam Turbine (“ST”) in this docket on March 1, 2019.  
16        Additionally, in last year’s docket I filed testimony and sponsored DEF’s Root Cause  
17        Analysis (“RCA”) regarding the same outage, which was attached to my testimony as  
18        Exhibit No. \_\_ (JS-1). This exhibit was then incorporated by reference into my March  
19        1, 2019 testimony in the present docket.

20

21 **Q.    Have your duties or responsibilities with the Company changed since you last  
22        filed testimony in this docket?**

23  A.    No.

1

2 **Q. What is the purpose of your testimony?**

3 A. The overall purpose of my testimony is to rebut OPC witness Polich's incorrect  
4 conclusion regarding the root cause of the L0 blade failures. DEF acted prudently at  
5 all times with respect to the operation of the Bartow plant. I will clearly articulate why  
6 the Commission should reject Mr. Polich's argument that DEF should bear any  
7 replacement power costs related to either the Spring 2017 outage or operation of the  
8 Bartow plant with pressure plates in place of the L0 blades in the steam turbine.

9

10 **Q. Please provide a summary of your testimony.**

11 A. The Commission should reject Mr. Polich's opinion as to the cause of the steam turbine  
12 ("ST") blade failures because he disregarded or ignored key information. Specifically,  
13 he only considered operating conditions for the Period 1<sup>1</sup> failure and disregarded key  
14 facts obtained from later operating periods that contradict his ultimate opinion. As my  
15 rebuttal testimony and exhibits demonstrate, DEF operated the Bartow unit at all times  
16 within the operating parameters set forth by the steam turbine Original Equipment  
17 Manufacturer ("OEM").<sup>2</sup> After DEF initially discovered damage to the L0 blades, it  
18 consulted with the OEM and adjusted operation to within new limits established by the  
19 OEM. However, even when DEF operated at lower LP pressure limits with the same  
20 type of blades as it did during Period 1, the L0 blades experienced damage. Mr. Polich  
21 ignores the fact that the L0 blades later failed even when DEF operated the Bartow unit

---

<sup>1</sup> My testimony refers to various periods of operation, which are set forth in my Exhibit No. \_\_ (JS-2), Table A.

<sup>2</sup> The OEM for the Bartow CC ST is Mitsubishi Hitachi Power Systems ("MHPS"). I will use "OEM" and "MHPS" in this testimony interchangeably.

1 at a lower LP pressure and claims that DEF's operation of the Bartow unit beyond its  
2 design during Period 1 caused the first blade failure.<sup>3</sup> The basis for his opinion appears  
3 to be an earlier root cause analysis that was prepared without the benefit of the  
4 additional information learned from continued operation of the unit in later periods.

5 Mr. Polich then concludes:

6 If DEF had operated the ST at BCC in accordance with design output of 420  
7 MW or less, I believe there is no engineering basis to conclude that the original  
8 L0 blades would not still be in operation today. Likewise, DEF would not have  
9 needed to undertake any of the subsequent outages to repair L0 blades,  
10 including the outage in February 2017 to replace the L0 blades with the pressure  
11 plate. Consequently, the BCC ST would currently be capable of producing its  
12 full output of 420 MW instead of being derated to 380 MW and operating with  
13 a less-than-optimal pressure plate.<sup>4</sup>  
14

15 These statements completely fail to account for subsequent failures that occurred  
16 without the ST being operated over, or even at, 420 MW of output. Contrary to Mr.  
17 Polich's suggestion, it is evident that DEF operated the machine prudently at all times  
18 and made a prudent decision to install the pressure plate in the spring of 2017 to allow  
19 for event-free operation while a long-term path forward could be designed, tested, and  
20 implemented. For those reasons, the Commission should reject Mr. Polich's contention  
21 that DEF should not be permitted to collect the replacement power costs incurred as a  
22 result of the 2017 outage and operation with the pressure plate and should approve  
23 DEF's recovery of its costs as presented in its petitions and testimony in this docket.  
24

25 **Q. Are you sponsoring any exhibits?**

---

<sup>3</sup> DEF's "operation of the BCC ST beyond the ST's 420 MW design" caused the first blade failure. Polich Testimony, pg. 7, ll. 15-16.

<sup>4</sup> *Id.* at pg. 8, ll. 11-18.

- 1 A. Yes. I am sponsoring:
- 2 • Exhibit No. \_\_ (JS-2) – *Exhibit No. \_\_ (JS-1) Revised as to Confidentiality Only*
- 3 *(Confidential)*;
- 4 • Exhibit No. \_\_ (JS-3) – *Duke Energy Bartow ST 40” Upgrade Blade Test in Takasago*
- 5 *Validation Rigor at MHPS (Confidential)*; and
- 6 • Exhibit No. \_\_ (JS-4) – *Bartow RCA Summary, Sept. 22, 2017 (Confidential)*.
- 7

8 **Basic ST Operation**

9

10 **Q. Based on Mr. Polich’s testimony, do you believe he understands how DEF controls**

11 **the Bartow ST during operation?**

12 A. No, his testimony shows that he focuses on the MW output of the machine as the control

13 mechanism, where in practice the output is simply the byproduct of operating the unit

14 within the design parameters provided by the OEM. At multiple times in his testimony,

15 Mr. Polich discusses the nominal nameplate rating of the Bartow ST (420 MW) as a

16 “design output” or “design condition”<sup>5</sup> and indicates his belief that the 420 MW

17 nameplate represents the unit’s “maximum gross output.”<sup>6</sup> However, thinking of the

18 operating parameters of a ST solely in terms of MW output is either an over-

19 simplification or miscomprehension of the true operating parameters of the unit and/or

20 the myriad variables that can impact the unit’s output. Despite the fact that Mr. Polich

---

<sup>5</sup> See e.g., *id.* at p. 8, l. 12; p.8, l. 10 (“generated output above the 420 MW design conditions”); p. 7, ll. 15-16 (noting the “ST’s 420 MW design.”); p. 8, l. 23--p. 9, l. 1 (“manufacturer’s 420 MW design conditions.”); p. 10, ll. 6-7 (“The ST was designed to produce 420 MW gross generation.”).

<sup>6</sup> *Id.* at p. 12, l. 13.

1 indicates his awareness of the true design conditions that govern use of the ST,<sup>7</sup> he,  
2 nonetheless, returns to the erroneous conclusion that the nameplate capacity is a  
3 “maximum” output threshold that cannot be breached.<sup>8</sup> In actuality, the nameplate  
4 capacity is simply the OEM’s expected output resulting from the operational  
5 parameters and other assumed values for variables that are given to fluctuation (such  
6 as ambient temperature, humidity, temperature of cooling water, etc.), not a design  
7 basis criteria for operating the ST.<sup>9</sup>

8

9 **Q. If the ST operating parameters are not centered on its output, what are the**  
10 **operating parameters established by the OEM for the Bartow ST?**

11 A. When the ST was commissioned in 2009, the operating parameters were established by  
12 the Mitsubishi ST operating manual as related to steam flow through the ST. When  
13 DEF realized that operating parameters allowed for additional steam to flow through  
14 the ST, resulting in additional megawatts for DEF’s customers while staying within  
15 those parameters, DEF started increasing the steam flow through the ST staying within  
16 the known operational parameters. After the original blade type was found to have  
17 cracking issues, DEF worked with Mitsubishi to establish additional operating limits  
18 not found in the operating manual. Each operating Period identified in Exhibit No. \_\_\_  
19 (JS-2) had different operating limitations.

---

<sup>7</sup> See *id.* at p. 11, ll. 11-17.

<sup>8</sup> See *id.* at p. 12, ll. 17-19.

<sup>9</sup> Considering Mr. Polich’s position that the ST had a MW output maximum that could not be breached without risking damage to the unit, it is noteworthy that he does not assign a similar “absolute maximum” to the other components of the Bartow CC. See *id.* at p. 9, ll. 21-22 (noting the “Non-steam augmented power output of each CT is in the range of 180 MW.”); p. 10, ll. 9-10 (noting the “generator output appears to have an upper gross generation limit of about 465 MW at a 0.95 power factor . . .”).

- 1           • Period 1 - Operational limits given to DEF were based on the turbine nameplate  
2           data and those limits typical for steam turbine operation like vibration limits,  
3           metal temperature ramp rate limits, seal system parameters, lube and hydraulic  
4           system pressure temperature limits and many other parameters that are common  
5           to this type of equipment. However, while parameters related to steam  
6           pressures and temperatures are part of the nameplate rating, no flow-limits, and  
7           in particular, no flow-limit for the LP turbine, were given to DEF. This is not  
8           unusual as flow limits will normally be maintained if inlet pressure and  
9           temperature limits are maintained. In a combined cycle application, that  
10          normally means staying within the pressure and temperature limits of the HP  
11          and IP turbines. There is only a small fraction of flow added by the HRSG LP  
12          system. In short, there was no operational limit for the LP turbine flow or inlet  
13          pressure for Period 1 that was known to DEF operations at that time.
- 14          • Period 2 - MHPS established a LP inlet pressure limit for DEF to follow. The  
15          LP pressure was inferred from the IP turbine exhaust pressure as no LP turbine  
16          inlet pressure instrument existed during this time period. During each  
17          succeeding time period, MHPS established a new LP pressure limit based on  
18          their analysis for the blade type and modifications installed at that time. A  
19          pressure transmitter was added to the LP turbine in the fall of 2016.
- 20          • Periods 3-5 - MHPS for the first time established an "Avoidance Zone" ("AZ")  
21          related to LP inlet pressure and condenser backpressure. For Period 3, MHPS  
22          stated that the AZ should be avoided but did not provide any time limits or  
23          recommendations to move the ST out of the AZ.

- 1 For the time-period that the Bartow ST has been operating with the installed pressure plate,
- 2 **MHPS has kept the LP inlet pressure parameter as a setpoint to not exceed even though the**
- 3 **L0 blades have been removed.**

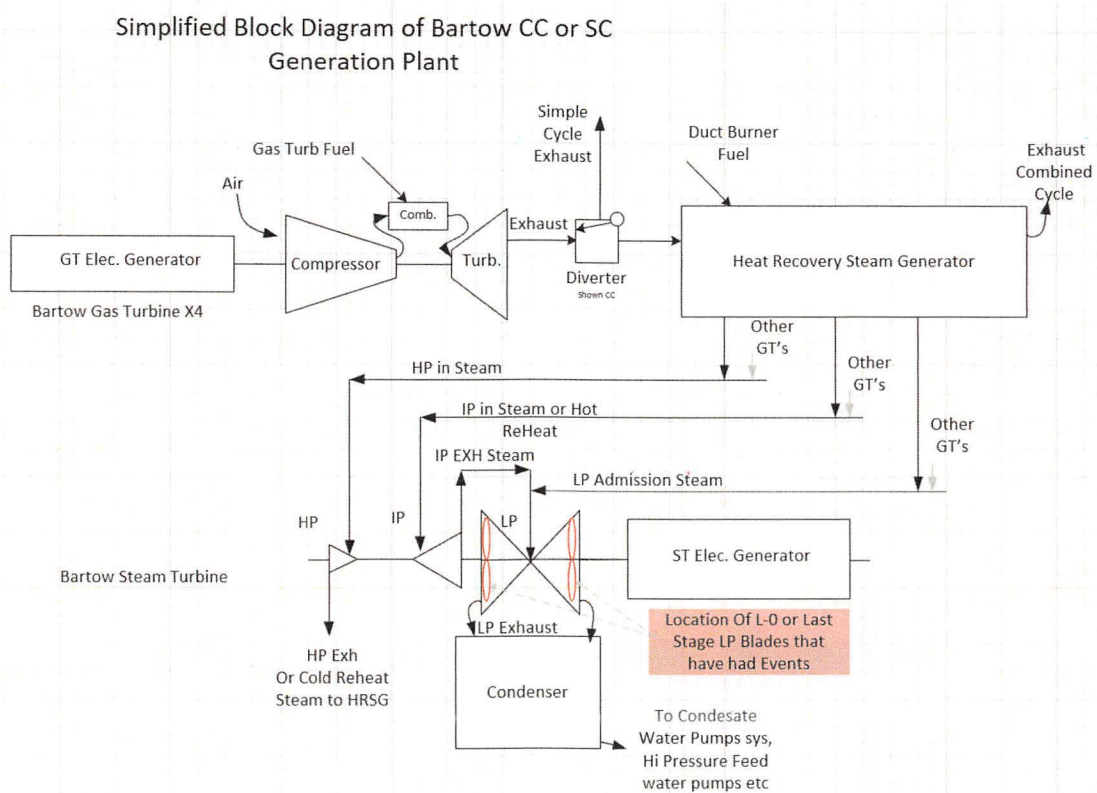

4

5

6 **Q. Did DEF operate the Bartow ST within the operating parameters established by**  
 7 **the OEM?**

8 A. Yes. Starting with commissioning and Period 1, DEF has followed all the known  
 9 operational limits for the steam turbine. Post-Period 1, DEF has made every reasonable  
 10 attempt to maintain the LP inlet pressure limit in place for the given Period. **Hours**

1 above the pressure limit do exist for Period 3;<sup>10</sup> however, during the testing period at  
2 the outset of Period 3, MHPS needed to explore the entire range of operational  
3 parameters in order to determine where dynamic stresses were above their limit at the  
4 time, resulting in many of the hours within the then-unknown AZ. MHPS established  
5 the AZ (additional instructions which consisted of a combination of LP inlet pressures  
6 and condenser backpressures) as a result of the post-test analysis of strain gage data  
7 gleaned from this testing, but MHPS was not able to analyze the data and communicate  
8 the limits of the AZ until March of 2015, therefore resulting in additional hours in the  
9 zone, albeit unbeknownst to DEF at the time of operation. Some additional run hours  
10 in the AZ do appear during Period 3, but operators adjusted the CTs and HRSG duct  
11 burner outputs to minimize time in the zone as they strove to maintain a high output  
12 and benefit from the steam turbine without compromise to the LP turbine. MHPS's  
13 instructions on time in the AZ was to limit the amount of time run there; it was not a  
14 hard-fast limit, nor did MHPS provide Bartow operators a means to automatically keep  
15 out of the AZ.

16  
17 **Q. If the plant operators do not control the ST by trying to reach a given level of MW**  
18 **output, how is the unit controlled?**

19 A. The ST is "controlled" by adjusting the output of the four combustion turbines ("CTs").  
20 For example, in a 1x1 configuration (one CT and heat recovery steam generator  
21 ("HRSG") providing steam to the ST), the ST would receive enough steam to produce  
22 approximately 100 MW; in a 2x1 configuration, the ST would receive the steam

---

<sup>10</sup> The chart titled "Excessive Steam Flow" found in Appendix B of Exhibit No. \_\_ (JS-2), shows the hours the unit was operated in the AZ for the respective Periods.

1 equivalent to approximately 200 MW; in a 3x1 configuration, the ST would produce  
2 about 300 MW; and for 4x1 configuration, the ST would produce about 400 MW. In  
3 order to produce more megawatts, the auxiliaries (duct burning and Power Augmented  
4 Steam (“PAG”)) would be used. These auxiliaries are described in more detail below.

5

6 The ST is a follower much like a trailer follows a truck. In this example, the trailer can  
7 only go as fast as the truck that is pulling it and can only turn if the truck makes a turn.

8 The four CTs exhaust into their respective HRSGs, the four HRSGs produce steam for  
9 the three sections of the ST. The HRSG produces high pressure (“HP”) steam,  
10 intermediate pressure (“IP”) steam, and low pressure (“LP”) steam. The HP steam  
11 enters the HP section of the ST, the IP steam enters the IP section of the ST, and the  
12 LP steam in the HRSG enters the LP section of the ST. The LP section of the ST also  
13 receives exiting steam from the IP section of the turbine. During the commissioning  
14 process, the ST is “matched” with the three steam pipes (HP, IP, LP) coming from the  
15 four HRSGs to produce the output of the machine in Megawatts. The output of the ST  
16 in megawatts is a product of the steam pressure and flow. If the operator wants to  
17 reduce the steam pressure and flow through the ST (i.e., to produce less Megawatts),  
18 the operator reduces the CTs’ output and thus the steam passing through the ST (and  
19 the megawatts produced) is reduced after a short lag in time for the energy to dissipate.  
20 The operator can also produce more output from the ST by adding duct burning within  
21 the HRSGs to produce more heat and therefore steam that is ultimately passed through  
22 the ST. The operator can also use PAG, another auxiliary, to produce more output from  
23 the power block. At first, PAG actually extracts steam from the IP section of the ST

1 using the steam in the CTs like a supercharger in a car and raising the output of the CT  
2 generators. If the operator uses PAG, the output of the ST is initially reduced until duct  
3 burning is introduced to produce more steam in the HRSG to send to the ST, raising  
4 the output of the ST generator.

5  
6 The ST has two (2) High Pressure stop valves and two (2) Control Valves. When the  
7 ST is online and steady state, all four (4) of these valves are open and stay open – no  
8 matter what configuration the station is operating in (i.e., 4x1, 3x1, 2x1, or 1x1). A  
9 combined cycle plant does not modulate its control valves to limit ST load, the control  
10 valves are only used in startup or shutdown to maintain system pressure above a  
11 minimum value. There are two automatic sub-systems associated with the ST to  
12 prevent too much steam from entering any of the sections of the ST (HP, IP, and LP):  
13 the “sky vents” and the condenser bypass system. The sky vents are located on the top  
14 of the HRSGs, and they sense pressure in the HRSG and can release steam from the  
15 HRSG in the event pressure rises above its setpoint. Use of the sky vents only occurs  
16 during an emergency or unit startup. The condenser bypass system is an automatic  
17 system designed to blend the HRSGs into and out of the ST. As the name suggests, the  
18 condenser bypass system takes steam from the HRSG and, instead of the steam entering  
19 the ST, it bypasses the ST and feeds directly into the condenser. The steam path  
20 described here can be traced through the diagram attached to Mr. Polich’s testimony as  
21 Exhibit No. \_\_ (RAP-3).

22

1 In summary, the operator controls the CTs and the output of the CTs determine the  
2 output of the ST. The operator's job is to make sure that the ST is operating as  
3 efficiently as possible, producing the most output for our customers as possible, within  
4 the steam pressure and flow limits (operating parameters) established by the OEM.

5 **Prudent Operation of the Bartow CC for DEF's Customers**

6

7 **Q. Is the distinction between operating to achieve a desired MW output as Mr. Polich**  
8 **describes and following the operating guidelines as you are describing important?**

9 **A.** Yes, it is important because operating with an eye to the proper operating conditions  
10 allows an operator to maximize a unit's efficient output for customers. As Mr. Polich  
11 notes, the Bartow CC is one of the most efficient and lowest-cost generation units in  
12 DEF's generation fleet. Therefore, it is prudent for DEF to maximize its output for  
13 customers' benefit, so long as the operating conditions prescribed by the OEM are  
14 complied with. Hence, when DEF became aware the unit was not being maximized  
15 according to the OEM's operating pressure, steam flow, and temperature guidelines,  
16 the prudent course of action for the Company was to bring the unit's operation into line  
17 with those guidelines – regardless of whether DEF was achieving the nameplate output  
18 previously.

19

20 If DEF were to operate the Bartow ST, or any other unit, according to Mr. Polich's  
21 concept of never breaching the nameplate "maximum" output, its customers would  
22 potentially experience higher costs. A simple way to illustrate the point is to consider  
23 winter versus summer operation. Due to cooler temperatures and denser, heavier air

1 conditions, a given unit can produce more MWs of output during the winter while  
2 operating within the same parameters as summer operation. Following Mr. Polich's  
3 logic, if DEF operated the unit during the winter without changing any of the operation  
4 parameters (e.g., no additional steam is being produced and put through the machine)  
5 and the output increased from 419 MW to 421 MW,<sup>11</sup> DEF would be required to "back  
6 off" operations in order to get the unit's output down below nameplate capacity; this  
7 would "cost" customers the opportunity to receive the otherwise free differential in  
8 output and would run counter to the goals of maximizing efficiency and value to  
9 customers.

10

11 **Q. Did DEF's customers benefit from the Bartow ST producing more than 420 MW**  
12 **during Period 1?**

13 A. Yes. When the Bartow ST was generating more than 420 MW during Period 1, it  
14 logically would have been dispatching in higher economic order than other generation.  
15 Accordingly, DEF avoided operating or buying more expensive generation, and DEF's  
16 customers received the benefit of this lower-cost power generation. This is of course  
17 how DEF should operate its generating fleet, as I describe above. In general, if DEF  
18 were to operate its fleet in the manner described by Mr. Polich, DEF would not be  
19 allowed to operate its units, including Bartow CC, in the most efficient manner. This  
20 would result in higher energy costs for DEF's customers due to the need to generate or

---

<sup>11</sup> Although in this example, the hypothetical increase in output for the ST during winter operation is set at 2 MW, in practice winter operations with no change in operation parameters can result in an approximate 95 MW increase for the Bartow CC, with approximately 15 MW of the increase attributed to the ST.

1 purchase higher cost energy, which is currently being served through lower-cost  
2 efficient unit operation.

3

4 **Root Cause of the L0 Blade Failure**

5

6 **Q. If the LO blade failures were not caused by operation of the unit beyond 420 MW,  
7 what was the cause?**

8 A. As explained in my previous testimony and more thoroughly in Exhibit No. \_\_ (JS-1)  
9 and Exhibit No. \_\_ (JS-2), the root cause of the blade failures, including the Period 1  
10 failure Mr. Polich focused on in his testimony, was the lack of design margin in the  
11 blades. Specifically, a lack of design margin in dealing with the dynamic steam forces  
12 present throughout the operating range of the steam turbine – both above and below  
13 420 MW. These steam forces are often referred to as dynamic flutter. MHPS identified  
14 dynamic flutter as the main root cause of the L0 blade failures in its later root cause  
15 report, conducted after the 2017 outage, as seen on page 12 of my Exhibit No. \_\_ (JS-  
16 4). Said differently, the different types of blades used during each period were not  
17 designed with sufficient operating margin to handle the steam flows, pressures and  
18 transient conditions to handle the dynamic steam forces present in the machine while  
19 it was being operated pursuant to the OEM's guidelines. I suspect that one of the  
20 reasons Mr. Polich reached his conclusion, which disregards the information gleaned  
21 from later operating periods, is because he chose to focus solely on Period 1 operation  
22 and he relied on early RCAs provided by the OEM rather than later-produced  
23 documents that benefited from this additional information such as DEF's RCA (Exhibit

1 No. \_\_ (JS-2)) and MHPS' confidential documents, attached as Exhibit Nos. \_\_ (JS-3)  
2 and (JS-4). As can be seen from Exhibit No. \_\_ (JS-3), MHPS recognized that its early  
3 RCAs did not identify the correct root cause of the damage. MHPS states "multiple  
4 forced outrages were experienced due to last stage blade damage caused by high load  
5 stimulus and high energy blending in the 4 on 1 configuration which was not fully  
6 understood until conducting an extensive collaborative RCA. Once the root cause was  
7 understood MHPS developed an upgraded 40" L-0 blade specifically to operate [in] the  
8 conditions present at Bartow."<sup>12</sup>

9  
10 **Q. Why is the later-Period operating information important to understanding what  
11 occurred in earlier Periods?**

12 A. Because as DEF and the OEM moved through the operating periods and learned more  
13 information, the information and conclusions derived were incorporated into later blade  
14 designs and operating limitations. After Period 1, MHPS believed as Mr. Polich now  
15 believes that the blade failure was a result of over-loading on the blades. However, the  
16 later-Period operating data directly refutes this conclusion. At multiple times in his  
17 testimony, Mr. Polich states a variant of his conclusion: "If DEF had operated the ST  
18 at BCC in accordance with the design output of 420 MW or less, I believe there is no  
19 engineering basis to conclude that the original L0 blades would not still be in operation  
20 today."<sup>13</sup> Indeed, Mr. Polich opined that DEF had not "demonstrated that the original

---

<sup>12</sup> Exhibit No. \_\_ (JS-3), page 2, bullets 2 & 3.

<sup>13</sup> Polich Testimony, p. 8, ll. 11-13; *see also id.* at p. 22, ll. 11-13 ("DEF has failed to demonstrate that had it operated the ST within original design conditions the original blades would still be in operation."); *infra* note 8.

1 L0 blades would have experienced even minimal degradation” had the unit been  
2 operated “at or below the original design output of 420 MW.”<sup>14</sup>

3  
4 These statements, and the general conclusion he reaches in his testimony, are  
5 conclusively refuted by the Period 5 operating experience. As shown on Exhibit No.  
6 \_\_ (JS-2), specifically Table A on page 5 of 18, in Period 5 the ST was operated with  
7 the same type of blades that were installed when the unit was operated in Period 1. The  
8 contrast between the results found in the two Periods shows why Mr. Polich’s  
9 conclusion is inaccurate. In Period 1, DEF operated the Bartow unit from June 2009  
10 to March 2012 according to the OEM’s original operating conditions (steam pressures,  
11 flows, and temperature – not to a maximum MW output), and as Mr. Polich points out,  
12 the unit achieved as much as 457.6 MW<sup>15</sup> before DEF discovered blade damage in  
13 2012. In Period 5, DEF operated the Bartow unit per new OEM-provided operating  
14 instructions that included reduced exhaust pressure operating limits, specifically a  
15 111.5 psig limit on the IP Exhaust,<sup>16</sup> that resulted in the ST achieving a maximum of  
16 402.1 MW of output.<sup>17</sup> Nonetheless, even with the new operating conditions, the  
17 blades failed after only 1,561 hours of operation leading to the February 2017 outage.<sup>18</sup>

18  
19 This information is crucial to understanding the root cause of the failures, including the  
20 Period 1 failure. As noted above, during both Periods 1 and 5 the ST operated with the

---

<sup>14</sup> See *id.* at p. 21, ll. 16-18.

<sup>15</sup> See *id.* at p. 15, l. 21; Exhibit No. \_\_ (RAP-5).

<sup>16</sup> Exhibit No. \_\_ (JS-2), Table A.

<sup>17</sup> Exhibit No. \_\_ (RAP-5).

<sup>18</sup> Exhibit No. \_\_ (JS-2), Table A.

1 same type of L0 blades (specifically, Type 1 blades<sup>19</sup>); that is, the same type of blades  
2 that Mr. Polich opined would not have failed in Period 1 had the ST not been operated  
3 beyond 420 MW failed in Period 5 even though the ST was always operated “at or  
4 below the original design output of 420 MW”<sup>20</sup> during that Period.

5  
6 Simply put, Mr. Polich’s contention that the original Type 1 blades from Period 1  
7 would still be in operation, without even minimal degradation, had DEF only operated  
8 the unit at or below 420 MW of output and that “all subsequent outages and derates  
9 since 2012 have their origin in the operation of the ST in excess of 420 MWs”<sup>21</sup> has  
10 been conclusively refuted by the Period 5 experience – Mr. Polich may not “believe  
11 there is [any] engineering basis to conclude” otherwise, but the facts and experience  
12 gained in Period 5 cannot be ignored.

13  
14 **Q. Mr. Polich also contends, based on his conclusion that DEF’s operation of the ST**  
15 **caused the original failure, that “all subsequent outages and derates since 2012**  
16 **have their origin in the operation of the ST in excess of 420 MW.” Do you agree**  
17 **with this statement?**

18 A. No. As discussed above, this is contradicted by the evidence of the later-Periods.  
19 However, if one were to assume for the sake of argument that Mr. Polich is correct, and  
20 DEF improperly operated the machine leading to the 2012 failure, that would not

---

<sup>19</sup> See Exhibit No. \_\_ (RAP-8), page 4 of 12, for an explanation on the different types of blades. Contrary to the assertions in Mr. Polich’s testimony, *see, e.g.*, p. 22, l. 15, “Type 2” blades were never installed in the Bartow ST. See Exhibit No. \_\_ (JS-2), Table A or Exhibit No. \_\_ (RAP-7), page 3 of 16, for discussions of the different types of blades installed at the unit in the different operating periods.

<sup>20</sup> See note 8, *supra*.

<sup>21</sup> See Polich Testimony, p. 22, ll. 10-11.

1 establish a causal link between the original blade failure and subsequent outages – nor  
2 does Mr. Polich suggest one. Rather, he offers a conclusory statement that ignores  
3 everything that occurred from Period 2 forward. In Periods 2-5, DEF operated the unit  
4 according to the OEM's updated operating conditions, and in Periods 3 and 4 installed  
5 redesigned blades that were intended to allow operation at the original operating  
6 conditions. Mr. Polich does not attempt to challenge these facts, rather he falls back  
7 on the logical fallacy of "because the later events followed the first, the first event must  
8 have caused them."

9  
10 Therefore, even if the Commission were to determine Mr. Polich was correct regarding  
11 operation of the unit in Period 1, he has provided no basis to conclude and it does not  
12 logically follow that the remaining outages and derates were caused by, or naturally  
13 flow from, that event.

14  
15 **Q. Are there other areas of Mr. Polich's testimony, beyond his conclusion regarding**  
16 **the root cause of the failures, where you disagree?**

17 A. Yes. I disagree with Mr. Polich's contention that DEF was somehow required to, or  
18 imprudent not to, discuss its operation of the Bartow ST with the OEM, specifically  
19 regarding the MW output being achieved. As discussed herein, Mr. Polich's focus on  
20 this lack of communication is a symptom of his focus on the nameplate rating as a  
21 "maximum" output and failure to accept that units such as the Bartow ST are operated  
22 based on steam pressures and flows, which is standard industry procedure, and that the  
23 output is simply a byproduct of that operation. With that understanding, it becomes

1 clear that no communication with the OEM regarding output was warranted or to be  
2 expected for normal operations within the operating parameters. Moreover, it is  
3 important to note that when DEF notified MHPS of the blade failure events, MHPS did  
4 not respond by asking what MW output the ST was achieving at the time of the failures.

5 I also disagree with Mr. Polich's speculative assertion that "[i]f DEF had discussed  
6 operation of the ST above 420 MW with MHPS prior to the initial operation at higher  
7 load, the problems encountered with the ST at BCC likely would have been avoided."<sup>22</sup>  
8 In order to make this assertion, Mr. Polich has to assume a number of premises that are  
9 either dubious or, given the experience of Period 5, we know to be outright wrong.  
10 First, Mr. Polich assumes that MHPS would have told DEF the machine could not be  
11 operated to produce over 420 MW output, when it is more likely from DEF's  
12 experience that MHPS would have referred DEF back to the operating parameters  
13 (steam pressure, flow, temperature, etc.) with which DEF was complying; thus, it is  
14 pure speculation to assert that any such communication would have led to any different  
15 action on DEF's part. Second, assuming DEF determined from that communication  
16 that operation of the ST needed to be curtailed, the experience of Period 5 cannot be  
17 ignored: operation at reduced steam flows and pressures resulted in significant blade  
18 damage and the February 2017 outage.

19 **Installation of the Pressure Plates**

20

21 **Q. Are there any other areas of Mr. Polich's testimony with which you disagree?**

---

<sup>22</sup> Polich Testimony, p. 22, l. 22 – p. 23, l. 1.

1 A. Yes, I disagree with the assertion that operation of the ST with the pressure plates  
2 installed has truly resulted in any lost MW when compared to the results achieved prior  
3 to their installation. After the February 2017 outage, DEF worked with the OEM to  
4 identify and implement an interim solution that would allow the ST to resume  
5 operation, ultimately resulting in the installation of a pressure plates in place of the L0  
6 blades on March 22, 2017. The plates allow the ST to operate, thus increasing the  
7 energy output of the Bartow CC above what was possible in simple cycle mode while  
8 a long-term path forward could be designed, tested, and implemented.

9  
10 When it became apparent that not even re-installing the original blade design, which  
11 had achieved the greatest run time, and operating at reduced operating parameters  
12 would result in event-free operation while the long-term solution work was ongoing,  
13 DEF was faced with a decision: install an iteration of blades that had previously failed  
14 in order to avoid a “derate” scenario (but risk further outages and potential damage to  
15 the rest of the ST) or install the plates and receive event-free output, albeit reduced  
16 from the nominal nameplate rating.

17  
18 I believe DEF’s decision to install the plates was prudent at the time it was made, and  
19 I think the results have benefitted customers as opposed to causing additional costs due  
20 to downtime from further L0 blade issues or potential catastrophic failure. Therefore,  
21 I do not believe the Commission should order a refund of any costs incurred due to  
22 operations after the plates’ installation.

23

1 Q. Mr. Polich has calculated replacement power costs that he contends should be  
2 refunded to customers due to operation of the Bartow CC with the pressure plates.

3 Do you agree with his calculation?

4 A. Setting aside my belief that DEF's prudent actions should not result in a refund of  
5 replacement power costs, if the Commission were to order a refund of replacement  
6 power costs due to operation of Bartow CC with the pressure plates, I disagree with  
7 Mr. Polich's inflated calculations.<sup>23</sup> He contends that operation of the ST from April  
8 2017 through August 2019 has cost customers approximately \$5.74M.<sup>24</sup> In response  
9 to a discovery request from OPC, DEF calculated the actual replacement power costs  
10 for the MWh's not produced at Bartow for the period (owing purely to the derate,  
11 ignoring the question of prudence) of \$1,168,613.

12

13 Based on DEF's analysis of his calculation as he described his method,<sup>25</sup> and using the  
14 values he included in Exhibit No. \_\_ (RAP-9), DEF has identified a number of issues  
15 that Mr. Polich's analysis fails to capture. For example, his analysis appears to fail to  
16 consider what configuration the Bartow CC was operating in at a given time, potential  
17 system constraints impacting dispatch of the unit (including transmission reliability  
18 restrictions),<sup>26</sup> ambient temperature conditions, plant conditions such as feedwater

---

<sup>23</sup> On page 25, lines 10-17, Mr. Polich describes a situation where DEF showed no replacement power costs for an 11-hour window on June 1, 2017. DEF believes Mr. Polich was referring to July 1, 2017, as the other metrics he cites align with that date.

<sup>24</sup> \$2,005,536 (2017) + \$2,545,049 (2018) + \$1,189,552 (2019) = \$5,740,137. See *id.* at p. 27, ll. 5, 12, & 20. It should also be noted that Mr. Polich stated Mr. Menendez's testimony in Docket No. 20180001-EI provide the costs of the 2017 Spring outage at \$11.1M – this is the system number; the retail portion of the total costs is approximately \$11.0M. See Document No. 07025-2018, Docket No. 20180001-EI, at p. 7, ll. 1-2.

<sup>25</sup> See Polich Testimony, p. 24, ll. 1-20.

<sup>26</sup> For example, there was no replacement power purchased on July 1, 2017 (discussed on page 25 of Mr. Polich's testimony) because the unit was not being dispatched high enough in the order to require replacement power.

1 limitations and any other environmental limits, to name a few. Failure to account for  
2 these additional factors results in an artificially high estimate of the replacement power  
3 costs for the MWh's not produced at Bartow. Therefore, DEF's estimate of  
4 replacement power costs, which takes into consideration these factors, is a more  
5 accurate estimate.

6

7 **Q. Does that conclude your testimony?**

8 **A. Yes.**

9

10

1 BY MR. BERNIER:

2 Q Mr. Swartz, have you prepared a summary of  
3 your rebuttal testimony?

4 A Yes, I have.

5 Q Could you go ahead and deliver that?

6 A Good morning again, Judge Stevenson.

7 The purpose of my rebuttal testimony is to  
8 explain why Mr. Polich's conclusions regarding causation  
9 are incorrect, and to provide further support for DEF's  
10 conclusion that the lack of blade design margin was the  
11 cause of the Bartow L0 blade failures.

12 As you have heard from Mr. Polich, his opinion  
13 is that DEF imprudently operated the Bartow steam  
14 turbine for two reasons, because the unit was operated  
15 in a manner that produced greater than 420 megawatts and  
16 because DEF failed to consult with Mitsubishi prior to  
17 doing so.

18 However, DEF did not imprudently operate the  
19 Bartow steam turbine. As I have previously testified,  
20 DEF operated the steam turbine in accordance with  
21 Mitsubishi's operating parameters. Simply put, the  
22 megawatt output is not an operating parameter of the  
23 steam turbine, rather operators are trained to monitor  
24 and comply with original equipment manufacturer-  
25 established limits pertaining to steam pressures, flows

1 and temperatures.

2           The megawatt output of the generator that  
3 results is a function of many factors. In fact,  
4 contrary to Mr. Polich's suggestion, DEF, like any  
5 prudent utility, was and should be pleased to find that  
6 operating within the established parameters was  
7 providing greater megawatt output than the minimum that  
8 was contractually guaranteed, because that means the  
9 machine was operating properly and efficiently. The  
10 extra megawatts produced are a benefit to customers,  
11 because it means those megawatts don't have to be  
12 produced with less efficient and more costly generating  
13 units.

14           Moreover, Mr. Polich's opinion focuses on only  
15 Period 1, and completely fails to account for the  
16 experience gained and lessons learned from later  
17 operating periods.

18           In order to validly conclude that the Period 1  
19 blades sustained damage because the unit was operated  
20 above 420 megawatts, one would have to explain why the  
21 later period blades also sustained damage without the  
22 unit being operated above that level.

23           However, Mr. Polich does not try to explain  
24 these occurrences. Instead, he speculates that had the  
25 unit not been operated above 420 megawatts in Period 1,

1 the original blades would still be in service, which  
2 allows him to conclude that everything that has occurred  
3 at Bartow can be traced back to the first period.

4 This conclusion ignores multiple intervening  
5 facts, including the installation of new blades with  
6 increased design margins to operate at greater pressures  
7 and more conservative operating parameters. What these  
8 facts tell us is that, notwithstanding DEF's compliance  
9 with the reductions in operating parameters Mitsubishi  
10 provided in each period, the L0 blades continued to  
11 suffer damage.

12 Importantly, in Period 5, when the unit  
13 operated with the same type of blades as Period 1, and  
14 the unit was operated according to the most conservative  
15 operating parameters provided by Mitsubishi, never even  
16 achieved 405 megawatts of generator output, the blades,  
17 nonetheless, suffered damage.

18 This experience clearly refutes Mr. Polich's  
19 conclusion, as is demonstrated by Mitsubishi's later  
20 documentation attached to my testimony as Exhibit JS-3.  
21 That document provides an overview of Mitsubishi's  
22 newest blade design and clearly shows Mitsubishi's  
23 ultimate position that it didn't fully understand the  
24 cause of the L0 blade failures until after the extensive  
25 collaborative RCA was concluded.

1           That document continues on to say that after  
2 the root cause was understood, Mitsubishi was able to  
3 design upgraded L0 blades specifically for the Bartow  
4 unit.

5           Mr. Polich also opined that DEF was imprudent  
6 because it failed to contact Mitsubishi before operating  
7 the steam turbine in a manner that produced more than  
8 420 megawatts of generator output. This opinion rests  
9 on the faulty premise that the capacity of the steam  
10 turbine generator was somehow an operating parameter  
11 that should not be breached without receiving prior  
12 clearance from the equipment manufacturer.

13           As I have discussed, that is simply incorrect.  
14 Rather, as long as the operator was staying within the  
15 operating conditions established by the OEM, that is the  
16 steam flows pressures and temperatures I discussed  
17 earlier, no prudent operator would feel compelled to  
18 contact the OEM to reverify the previously provided  
19 operating parameters.

20           Additionally, in any conversation with the OEM  
21 regarding operation beyond a given electrical output  
22 level would revert instead to a discussion of the  
23 operating parameters I have discussed above. Operators  
24 and equipment manufacturers do not discuss operation of  
25 a steam turbine in terms of electrical output, but in

1 terms of pressures, temperatures and steam flows.

2 Thank you.

3 MR. BERNIER: Judge, we would now tender  
4 Mr. Swartz for short cross.

5 THE COURT: With that restriction, Mr.  
6 Rehwinkel.

7 MR. BERNIER: It's on the record, lawyer.

8 MR. REHWINKEL: I usually don't agree with Mr.  
9 Bernier, but I agree with him, this will be short.  
10 So I adhere to his restrictions.

11 EXAMINATION

12 BY MR. REHWINKEL:

13 Q Hello again, Mr. Swartz.

14 A Good morning.

15 Q Hopefully for the last time in this whole  
16 process.

17 On, I guess, page nine of your rebuttal  
18 testimony, you have a -- starting on line six, you have  
19 a long discussion about Duke's view, or your view that  
20 the steam turbine is a follower?

21 A Yes, sir.

22 Q Okay. And is that consistent also with page  
23 17, lines 22 and three, where you say: And the output  
24 is simply -- and that the output is simply a byproduct  
25 of that operation; are those the same concepts?

1           A     They are.

2           **Q     Okay.  So can you tell me if the Bartow plant**  
3 **produces sufficient steam with four CTs operating at**  
4 **full capacity and no supplemental firing -- firing of**  
5 **the HRSGs to power the steam turbine to produce**  
6 **420 megawatts?**

7           A     I don't know if it does that.  Could you --  
8 without duct firing, is that your question?

9           **Q     Yes.  Let me just make sure that we get this**  
10 **right.  Can the plant produce sufficient steam with four**  
11 **CTs firing at full capacity and no supplemental firing**  
12 **of the HRSGs to power the steam turbine to produce**  
13 **420 megawatts?**

14          A     I don't know what the operating output of the  
15 generator would be at 4-on-1 configuration without duct  
16 firing.  I don't know that operating parameter, or that  
17 set point -- or what that capacity would be at the  
18 output.

19          **Q     If Bibb's heat base -- what do we call those**  
20 **things?**

21          A     The heat --

22          **Q     Balance --**

23          A     Yes.

24          **Q     -- case 44 said that, would you accept that**  
25 **subject to check?**

1           A       I think heat balance case 24 is 4-on-1  
2 unfired, and it showed 389 megawatts.

3           **Q       But would you -- so is it your view that**  
4 **that's probably correct, you wouldn't have enough steam?**

5           A       That's correct. For all -- remember each of  
6 those heat balance cases have dozens of variables --

7           **Q       Sure.**

8           A       -- and there is different pieces of equipment  
9 that are in service. So, yes, for heat case 24, with  
10 all of those different variables, 389 megawatts was the  
11 predicted output.

12          **Q       Okay. And doesn't the operation of the steam**  
13 **turbine above 400 megawatts require the HRSGs to have**  
14 **some amount of supplemental firing to produce sufficient**  
15 **steam?**

16          A       I don't know that.

17          **Q       Do you know that not to be the case?**

18          A       I don't know that not to be the case either.

19          **Q       Well, do you at least need supplemental firing**  
20 **to get above 420 megawatts at the unit?**

21          A       Again, I don't know. There is a lot of  
22 different combinations we can operate this unit in, and  
23 depending if it's a winter operation or a summer  
24 operation and what all the variables are, I just don't  
25 know.

1           **Q     Did Duke ever get above 420 during Period 1**  
2     **without supplemental firing?**

3           A     I don't know.

4           **Q     Do you know whether the unit, the steam**  
5     **turbine requires more supplemental firing when it's at**  
6     **400 megawatts versus 420?**

7           A     I don't know. There is a lot of factors that  
8     would go into that. And again, I just don't have that  
9     in-depth knowledge of all the variables taking place at  
10    that station to get a certain output.

11          **Q     Isn't it true that Duke can limit the steam**  
12    **turbine output when operating above 400 megawatts by**  
13    **merely controlling the amount of supplemental firing?**

14          A     If supplemental firing is in service, that is  
15    a control mechanism for output of the power block. That  
16    is accurate.

17                   MR. REHWINKEL: Okay. I have no further  
18    questions, Your Honor.

19                   MR. MOYLE: I have short inquiry.

20                   THE COURT: Sure.

21   EXAMINATION

22    BY MR. MOYLE:

23          **Q     Good morning.**

24          A     Good morning.

25          **Q     The expert witness that you filed the rebuttal**

1 to, that Office of Public Counsel sponsored, you don't  
2 take quarrel with any of his qualifications, do you?

3 A Not at all.

4 Q And yesterday, when we were talking, we went  
5 through the people that have looked at this issue in the  
6 Duke team, seven-member root cause team of which you  
7 were not a part, correct?

8 A That's correct.

9 Q And also Mitsubishi looked at it, right? They  
10 did their own root cause?

11 A That's correct.

12 Q And now Office of Public Counsel has hired an  
13 expert to look at it, right?

14 A That's right.

15 Q And that is the universe of people that have  
16 looked at it, correct?

17 A Yes, that's accurate.

18 Q And out of those groups, the only one that is,  
19 you know, not affiliated or, you know, an independent  
20 expert is OPC's witness, correct?

21 A Yes.

22 MR. MOYLE: That's all I have.

23 THE COURT: Anything from PCS, Mr. Brew?

24 MR. BREW: Yes, thank you.

25 EXAMINATION

1 BY MR. BREW:

2 Q Good morning, Mr. Swartz.

3 A Good morning.

4 Q First, yesterday I handed you a document that  
5 we didn't get to. Do you have it with you?

6 A I apparently stole them and put them over  
7 there.

8 MR. BERNIER: Do you have an exhibit number?

9 MR. BREW: Well, it's going to be 112. It's  
10 the thicker one.

11 THE COURT: It's 112.

12 THE WITNESS: Okay, I have it.

13 BY MR. BREW:

14 Q All right. I just want to identify it first.

15 Would you agree that this is a document that  
16 Duke provided under your signature in response to a  
17 Public Counsel data request?

18 A Yes.

19 Q And it's entitled on the first real page,  
20 Bartow Steam Turbine Path Forward Recommendation, dated  
21 May 29th, 2018 do you see that?

22 A Yes, I do.

23 Q Okay. So this is a document that Duke  
24 provided in discovery?

25 A Yes.

1 Q Okay. Thank you.

2 Your rebuttal has three exhibits, JS-2, 3 and  
3 4. JS-2 is a reprint of the root cause analysis that  
4 was provided earlier that was roughly discussed in  
5 direct, right?

6 A Correct.

7 Q And JS-3 is entitled on the front page, Duke  
8 Energy Bartow ST 40-inch upgrade blade test in Takasago,  
9 which you would describe as a description of the newest  
10 blade design?

11 A Yes, that's correct.

12 Q And so is that a description of the 40-inch  
13 upgraded blades that have recently been installed at  
14 Bartow?

15 A Yes.

16 Q Okay. So is that was the winning bid and the  
17 technology that was selected?

18 A It was.

19 Q Okay. So if I can refer you to that document,  
20 page two of two, that's labeled introduction. Do you  
21 see it?

22 A Yes, two of 22.

23 Q Two of 22, that's correct.

24 The first three statements in the  
25 introduction, which is sort of a statement of the

1     **problem being addressed, do you agree with each of those**  
2     **statements?**

3           A     Not completely, no.

4           **Q     Okay. And it was based on those statements**  
5     **that Mitsubishi was designing a solution to, right?**

6           A     I think it was based on a lot more than those  
7     statements, but that's part of it.

8           **Q     So moving further down, Mitsubishi says: To**  
9     **achieve confidence in the capability/reliability of a**  
10    **new blade, extensive testing was conducted.**

11                   **Wasn't it done to resolve the problems that**  
12    **were described up front in the first three bullets?**

13           A     Well, testing was conducted to make sure that  
14    the new design was adequate to meet the needs of the  
15    request for proposal.

16           **Q     Okay. Can we agree that the multiple forced**  
17    **outages that we discussed yesterday were experienced due**  
18    **to last stage blade damage caused by high load stimulus**  
19    **and high energy blending of the 4-on-1 configuration?**

20           A     Could you say that again, please?

21           **Q     I am reading from the third bullet.**

22           A     Okay. I think there is a better spot in JS-4  
23    in the Mitsubishi document that also has a similar  
24    statement that I think much better explains it. If you  
25    turn --

1           **Q**     Okay. Well, JS-4 is Mitsubishi's root cause  
2     **analysis, right?**

3           A     It's says RCA summary.

4           **Q**     Okay. So it's a summary of their position,  
5     **okay. So if you want to refer to a statement there, go**  
6     **ahead.**

7           A     If you go to page 12 of 35 of that document.  
8     And at the very bottom of page 12 of 35, in a red box in  
9     bold print, because it's so important, root cause  
10    analysis has identified all blade damage from Period 1  
11    through Period 5 has been identified as dynamic loads  
12    from non-synchronous self excited vibration, or flutter.

13          **Q**     Okay. Do you agree with that?

14          A     I do.

15          **Q**     The document that I showed you, if you could  
16    **refer to that now.**

17          A     Okay.

18          **Q**     And could we agree that this is a document  
19    **prepared by Duke Energy that is a summary of the**  
20    **competing solutions for the permanent repair of the low**  
21    **pressure turbine?**

22          A     Yes. As it says, it's a working draft of the  
23    team that was working on that.

24          **Q**     Okay. Could you refer to Bates number page  
25    **1606?**

1           A       Okay, I am there.

2           **Q       Do you have it?**

3           A       I do.

4           **Q       Okay.  And this page contains Duke's**  
5           **categories for weighting and evaluating the proposed**  
6           **solutions to its turbine problem, right?**

7           A       Yes, it does.

8           **Q       And specifically with respect to future**  
9           **operations, they placed a heavy weighting on**  
10          **restrictions of blending, restriction on condenser back**  
11          **pressure and max flow limitations, right?**

12          A       Yes.

13          **Q       Okay.  And those are precisely the situa --**  
14          **the concerns that led to the original establishment of**  
15          **the avoidance zone, isn't that right?**

16          A       Back pressure was part of the establishment of  
17          the avoidance zone.  I don't see the LP inlet pressure  
18          in that section.

19          **Q       Would that come in under max flow limitations?**

20          A       It would.  Good point.  Yes, sir.  That's  
21          right.

22          **Q       Okay.  So, in effect, the weighting criteria**  
23          **designed to resolve the underlying problems that had**  
24          **been observed?**

25          A       Yes.

1           **Q**     That had actually been observed based on the  
2 blade vibration and telemetry testing that had been  
3 conducted in 2014?

4           A     Yes.

5           **Q**     Okay. And we discussed that, in fact, Duke  
6 selected Mitsubishi's proposal to upgrade and redesign  
7 the blade as the solution?

8           A     Yes.

9           **Q**     And the redesign of the blade has not changed  
10 the level of loading or the condenser we discussed  
11 yesterday?

12          A     Correct.

13          **Q**     Okay. And as a part of the solution, Duke  
14 required and Mitsubishi agreed to permanently install  
15 blade vibration monitoring?

16          A     Yes.

17          **Q**     So that --

18          A     Let me correct that. Duke -- that was part of  
19 what we -- it was a big part of the decision. We, Duke,  
20 wanted permanently mounted blade vibration monitoring  
21 system.

22          **Q**     Right.

23          A     It wasn't -- it sounded like you were saying  
24 Mitsubishi wanted that. Duke Energy wanted that.

25          **Q**     You wanted it, Mitsubishi agreed to do it?

1           A       Correct.

2           **Q       It's been installed?**

3           A       Correct.

4           **Q       Precisely so that you have an independent way**  
5 **of monitoring potential excessive blade vibration?**

6           A       Correct.

7           **Q       Okay. So if I can refer you to your JS-4,**  
8 **page 28 of 35. And again, this is -- we are talking**  
9 **about this is a Mitsubishi prepared document, right?**

10          A       It is. Yes.

11          **Q       Okay. And it's entitled upgraded blade to**  
12 **achieve 450 megawatts available by October 2018, right?**

13          A       Yes.

14          **Q       Okay. And the upgraded blade is the very**  
15 **upgraded blade that you discussed and is reviewed in**  
16 **JS-3?**

17          A       The concept is the same. I don't know whether  
18 it's specifically the same, because during the process  
19 of moving forward with the -- this is an RCA summary, so  
20 Mitsubishi had an idea, but then later in time, Duke  
21 Energy issued a request for proposals for the long-term  
22 solution. What ultimately came back from Mitsubishi may  
23 have been slightly different than this, but the concept  
24 is the same.

25          **Q       The concept is the same?**

1           A     Yeah.

2           **Q     So item No. 5 on that page, which is entitled**  
3 **Bypass Operating Guidelines, do you see it?**

4           A     I do.

5           **Q     Could you read it, what it says under the**  
6 **heading?**

7           A     If required based on telemetry test results,  
8 operating guidelines for bypass can reduce blade  
9 response by minimizing operation of C and D bypass at a  
10 mach number greater than 0.55. DCS controls update  
11 strategy is an evaluation.

12          **Q     So do I take it from that that Mitsubishi was**  
13 **saying that based on telemetry test results, once they**  
14 **are in operation, you could still see operating**  
15 **restrictions during certain high energy bypass?**

16          A     That's what they are saying here, is that if  
17 the telemetry test shows that, we may have to change the  
18 way we blend, especially the C and D HRSGs.

19                 MR. BREW: Okay. Thank you, that's all I  
20 have.

21                 THE COURT: Anything?

22                 MS. BROWNLESS: We have no questions, Your  
23 Honor.

24                 THE COURT: Okay.

25                 MR. BERNIER: I do have a couple quickly.



1     **instructions for the Bartow steam turbine, is that**  
2     **correct?**

3           A     Yes.

4           Q     **And they were written operating instructions,**  
5     **is that correct?**

6           A     Yes, that's correct.

7           Q     **Okay. And at the end of Period 2, the Period**  
8     **3 blades were being inserted in the machine, did Duke**  
9     **Energy find damage to those Period 2 blades?**

10           MR. REHWINKEL: Your Honor, I am going to  
11           lodge an objection. I asked a series of questions  
12           that were asked about whether supplemental firing  
13           was needed to get the output of the unit above 400  
14           or 420. This recent question has nothing to do  
15           with the scope of my cross-examination, and I think  
16           it's outside.

17           THE COURT: That's a little beyond the scope.

18           MR. BERNIER: I would agree. I withdraw the  
19           question.

20           We have nothing further.

21           THE COURT: Thank you, Mr. Swartz.

22           (Witness excused.)

23           THE COURT: And I believe that brings us to  
24           closing statements. Do the parties want to take a  
25           break before we get to that, or are you ready

1 plunge in?

2 MR. BERNIER: I can tell you, Judge, I didn't  
3 intend to make a closing statement. I was thinking  
4 we would use that as our PRO.

5 THE COURT: And that's fine. I mean, if you  
6 even want to submit supplemental, you know, a  
7 closing statement in writing with the PRO, I mean,  
8 that would be fine with me as well if you don't  
9 want to do it.

10 MR. MOYLE: I'm happy to do it. It would be  
11 brief, but I think we can do it.

12 THE COURT: Okay.

13 MR. BERNIER: In that case, I will reserve the  
14 right to make a closing statement based on what Mr.  
15 Moyle says.

16 THE COURT: Okay. Well, who should we  
17 start -- well, Mr. Moyle has stepped up, so I  
18 suppose --

19 MR. MOYLE: Yeah --

20 MR. REHWINKEL: I would say the Public Counsel  
21 did not contemplate making any, and I think we  
22 would stand on our written filing. And if we need  
23 to make a supplemental statement that would have  
24 been a closing today, we will do that in our --

25 THE COURT: I did just have one housekeeping

1 matter. Mr. Brew, did you want to move Exhibit  
2 112?

3 MR. BREW: Yes, Your Honor, please. I wanted  
4 to move what had been marked as Exhibit 112 for  
5 identification into the record.

6 THE COURT: We will show 112 admitted.

7 (Whereupon, Exhibit No. 112 was received into  
8 evidence.)

9 MR. MOYLE: Your Honor, another housekeeping  
10 matter, the only document we used was the EIA  
11 document that we handed out yesterday. I don't  
12 think it was marked, but --

13 THE COURT: The glossary?

14 MR. MOYLE: Yeah, the glossary. If we could  
15 go ahead and give that a number and move it.

16 THE COURT: Any objection to that? I think we  
17 are up to 118 now. We will mark that as Exhibit  
18 118 and show that admitted.

19 (Whereupon, Exhibit No. 118 was marked for  
20 identification and received into evidence.)

21 MR. BERNIER: I am sorry, Judge, I need to  
22 move Mr. Swartz's rebuttal exhibits in as well. I  
23 believe they are 80, 81 and 82 -- yes, that's  
24 correct -- on the comprehensive exhibit list.

25 THE COURT: And we will show those, 80, 81 and

1           82 admitted, that's J-2, J-3 and J-4.

2                   (Whereupon, Exhibit Nos. 80-82 were received  
3 into evidence.)

4           THE COURT: I think that's everything now.  
5           Mr. Moyle.

6           MR. MOYLE: Thank you, Your Honor.

7                   And thank you, we had, I think, an orderly  
8 hearing, and I want to compliment the Public  
9 Service Commission, Ms. Brownless, for guiding us  
10 guiding us through this, and thank you for the time  
11 and attention that you have given to us.

12                   I am a big fan of sticking to agendas, and she  
13 had the closing statement in there, so I just want  
14 to share a few thoughts. I won't belabor points.

15                   But I think at the outset, you asked a  
16 question about burden of proof, and everyone agreed  
17 that Duke has the burden of proof in this case.  
18 And respectfully, we don't believe that that burden  
19 was met for, you know, for a number of reasons.

20                   There have been three analyses of what caused  
21 this problem. And there are sometimes different  
22 words that were used. Just in the last witness,  
23 the maximum flow limitations, the low pressure  
24 turbine exceeds the steam flow. Mr. Brew, I think  
25 asked the witness, doesn't it mean too much steam?

1 In my vernacular, too much steam is, if you know a  
2 chief cause here.

3 Duke said in their root cause analysis that  
4 the low pressure turbine excessive steam flow. And  
5 that has been listed. You have seen that in these  
6 documents, both in the drafts, and it appears a lot  
7 of places.

8 And then the OPC expert witness essentially  
9 said that they had generated more than the  
10 420-megawatt and subjected the L0 blades to forces  
11 25 percent greater than designed operating  
12 conditions.

13 So in slightly different ways, I think you  
14 have evidence before you that suggests that too  
15 much steam in an operation was -- surely hasn't  
16 been ruled out as a cause. And I think there is a  
17 lot of evidence that suggested it was a cause.

18 The only independent expert to look at this  
19 has been OPC's witness. And Duke folks are good  
20 folks, as I think we said, but, you know, they had  
21 an internal team of investigators that looked at  
22 it.

23 During one of the witness' testimony, they  
24 said, well, there might be some litigation. There  
25 was a settlement that was reached. You know,

1 Mitsubishi said, well, Duke, you guys didn't  
2 operate it right. Duke said, well, we think  
3 Mitsubishi, you know, it was their fault.

4 And as we said, no one suggested that it's the  
5 ratepayers' fault, but in this situation, dealing  
6 with an amount that is about one percent of the  
7 amount that Duke has already recovered, we think  
8 that Duke has not carried their burden of proof.

9 And there is another issue that I wanted just  
10 to bring to the, you know, to the Court's attention  
11 is -- and we didn't talk about it, but, you know,  
12 hearsay is treated in Chapter 120 as something that  
13 can be used if it is corroborated by other  
14 non-hearsay evidence. And the root cause report of  
15 Duke, I would argue, was hearsay. It was a report  
16 that was put together by seven Duke individuals.  
17 There was testimony about who wrote it, who the  
18 scribe was. And the witness, Mr. Swartz, for Duke,  
19 he was asked a whole slew of questions, and he took  
20 his best shot at it. But a lot of times he said,  
21 well, I am assuming, and I am speculating, and it  
22 was, I think, telling that the record, I believe  
23 you will find, is full of those hedges on different  
24 things when he was asked questions.

25 And I noted yesterday when I was crossing him,

1           there was a line in one of the documents that said,  
2           quote, we've had bad blends during all five periods  
3           of operation. And there has been a lot of  
4           discussion about blending, and the steam, and I  
5           think it ties into the excessive steam flow. But  
6           the witness, he said, well, you know, I interpret  
7           that to mean high pressure, I believe.

8                     I mean, he was making an interpretation of the  
9           word, bad, that was just his view because he was  
10          given a document that he didn't have great insight  
11          into when it was being crafted and put together,  
12          and is, you know, is rendering an opinion on a  
13          hearsay document.

14                    So I think when you consider that in  
15          conjunction with, you know, the burden of proof in  
16          this case, that the evidence suggests that Duke did  
17          not carry their burden, and for that reason, the  
18          decision should be that they didn't carry their  
19          burden to show that they were -- would be entitled  
20          to this money.

21                    And we will submit, either jointly or  
22          separately, proposed recommended orders that will,  
23          I think, detail some of this, but we wanted to  
24          share this with you now while it's still fresh, and  
25          we appreciate the opportunity to do so.

1 THE COURT: Thank you.

2 MR. BREW: Thank you, Your Honor. I  
3 appreciate the time to make a short statement.

4 In many of our PSC dockets, Mr. Moyle is known  
5 for using a car analogy, so pardon me if I steal  
6 his thunder.

7 You can drive a four-cylinder Ford Fiesta like  
8 a V8 Ferrari, but it's not quite the same thing.  
9 At 4,000 RPMs, in second gear, the Ferrari is  
10 already doing 60 and it's just warming up. The  
11 Ford Fiesta, however, will be moaning and begging  
12 you to slow down and shift gears. And that's kind  
13 of what we are talking about here.

14 It's conceded as fact that the root cause of  
15 the Bartow low pressure turbine problems is  
16 excessive vibrations caused reputedly over time.  
17 The answer to the question is was this due to the  
18 way Duke ran the plant or is it due to a design  
19 flaw? Well, the answer is both.

20 The fact is is that Duke bought a steam  
21 turbine that was already built for a different  
22 configuration that was in storage, and then hooked  
23 it up to a configuration, a four-by configuration  
24 that it knew could produce much more steam than it  
25 needed. It had a generator that could produce more

1 megawatts, so the limiting factor was the steam  
2 turbine.

3 On its own initiative, it decided to push more  
4 steam through the steam turbine to get more  
5 megawatts until it broke.

6 When they asked Mitsubishi about it, and you  
7 will see that on the Table A on the root cause  
8 analysis that we referred to, the first thing that  
9 Mitsubishi asked them do was to reduce the steam  
10 flow, reduce the inlet pressure from the turbine.

11 So in Period 2, you will see that the first  
12 thing they established was a limit on the pressure  
13 coming into the low pressure segment.

14 In Period 3, they added to that, by not only  
15 limiting the inlet pressure, but looking at the  
16 condenser back pressure. So they were still --  
17 Mitsubishi, while they were trying to figure out  
18 what do about the blade design, particularly in the  
19 4-x-1 configuration, which is unique to this plant,  
20 and Duke had no prior experience operating in that  
21 configuration, and Mitsubishi did not have any  
22 experience in its entire global fleet with an  
23 operation at these steam pressures, the whole point  
24 was to establish that avoidance zone.

25 Now, what they have come up with is another

1 blade design fix, but they haven't changed any of  
2 the underlying conditions that are causing the high  
3 energy blending, the limits in the condenser that  
4 are causing those conditions in the first place.

5 So from our perspective, Duke clearly was at  
6 fault for pushing excessive steam flow into the  
7 turbine in the first place. The repair which has  
8 been established which may or may not work, but the  
9 early operation clearly impeded Duke's ability to  
10 simply claim that Mitsubishi was entirely at fault.  
11 And under those circumstances, it's not appropriate  
12 to assign the cost to the consumers.

13 Thank you.

14 THE COURT: No other takers? Duke?

15 MR. BERNIER: I will be very brief.

16 I will discuss, I think, Mr. Moyle's  
17 non-contemporaneous hearsay objection in our  
18 closing -- or in our PRO.

19 And I would agree, I think, with part of what  
20 Mr. Brew said, that as damage was found in the  
21 blades, Mitsubishi did continue to lower the  
22 operating parameters, but I think it's clear that  
23 the only evidence in the record is that at all  
24 times, Duke operated according to the limits that  
25 Mitsubishi had provided, which is the industry

1 standard, and the blades failed. That's what the  
2 root cause analysis shows, but the remainder we  
3 will handle in our PRO.

4 THE COURT: Very good.

5 It's my understanding that the parties have  
6 agreed that the PROs will be due 30 days from  
7 today, is that the agreement? I said it was --  
8 typically, we start our clock running from the  
9 filing of the transcript, but 30 days from today is  
10 fine.

11 There was something else I wanted to ask you  
12 and now I have forgotten.

13 MR. MOYLE: Ask can I ask a question on that?

14 THE COURT: Sure.

15 MR. MOYLE: In terms of the transcript, it's  
16 going to go to the PSC, and then I am just  
17 wondering when we will see it. 30 days is fine  
18 provided we, you know, we see it.

19 THE COURT: You don't get the transcript on  
20 the 25th day?

21 MR. MOYLE: Right.

22 MR. BERNIER: So can I -- because we have to  
23 make a confidentiality filing, right, and it can't  
24 go to the PSC until I make that filing, so what I  
25 would propose, if this works -- I don't know if you

1           need to take this down or not -- when you have the  
2           transcript prepared, let me know. I will make a  
3           filing, and then when you provide it to Public  
4           Service Commission, which will have to be in hard  
5           copy, and you can send me a copy, I will get it to  
6           everybody that same day you provide it to me. That  
7           will give me the chance to make the confidentiality  
8           filing and then it can be filed with DOAH  
9           confidentially as well. Does that work?

10                         (Discussion off the record.)

11           MS. BROWNLESS: In our joint motion for  
12           confidentiality, which Judge Stevenson has already  
13           approved, we discussed in paragraph 5A how  
14           post-hearing submittals would be handled. We also  
15           discussed how the transcript would be handled, and  
16           that -- and this is what we said:

17                         When the transcript of the hearing is  
18           prepared, the PSC Clerk shall notify DEF, who shall  
19           file a Notice of Intent for the transcript with the  
20           Commission Clerk and file the trans -- and file a  
21           RFCC -- I don't remember what that means -- for the  
22           information -- request for confidential  
23           classification, sorry. I lost my head there -- for  
24           the information within 21 days thereafter as set  
25           forth in the rule. So --

1           MR. BERNIER: I appreciate you reminding me of  
2           that. I had forgotten. We will follow the order  
3           as drafted.

4           THE COURT: I had forgotten and I entered the  
5           order.

6           MS. BROWNLESS: Right. And then there is  
7           post-hearing submittals, a hard copy of all of the  
8           proposed recommended orders shall be filed with the  
9           commission via nonelectronic means via  
10          hand-delivery, UPS, Federal Express, et cetera.

11          A cover letter shall accompany the PRO stating  
12          that the PRO contains confidential information and  
13          should not be made available to the general public  
14          on DOAH's website. Parties with the exception of  
15          the PSC staff may be served electronically by any  
16          means agreeable to the parties. A hard copy of  
17          each PRO shall be filed with the PSC clerk via  
18          nonelectronic means with a cover letter. So --

19          THE COURT: We were better prepared than we  
20          thought, or even remember.

21          MS. BROWNLESS: That's what we worked out.

22          MR. BERNIER: That was incredible.

23          MR. REHWINKEL: So just to be -- just to  
24          hopefully but the put a bow on this. We have an  
25          indeterminant date for when the transcript will

1 trigger the 30-day period. That 30 days will start  
2 when Duke files the Notice of Intent with the  
3 Commission, is that what we -- because the  
4 transcript will --

5 MR. BERNIER: That works for us.

6 MR. REHWINKEL: Then the 30-day period, it  
7 might fall on a Saturday or a Sunday, so the close  
8 of business --

9 THE COURT: On a business day.

10 MR. REHWINKEL: Yes.

11 THE COURT: The next business day.

12 MR. REHWINKEL: Right, that's our  
13 understanding.

14 THE COURT: A weekend or a holiday, yeah.

15 MR. REHWINKEL: Yeah. And I think we probably  
16 will work among ourselves to make sure we all agree  
17 with that interpretation so we are all on the same  
18 page, because we can't file a paper on a weekend.

19 MR. MOYLE: Yeah. Just one point. So I think  
20 my chief concern in raising this was having the  
21 transcript for a period of time. When you file  
22 your notice, we will get it that day --

23 MR. BERNIER: Yes.

24 MR. MOYLE: -- because you will be filing --  
25 okay, we don't have to wait on the PSC to process

1           it and get an order?

2           MR. BERNIER: Right.

3           MR. MOYLE: Okay. We are good.

4           THE COURT: And I will endeavor -- I will make  
5           best efforts to get my RO out within 30 days of the  
6           filing of the PROs, with the understanding that  
7           this is a complicated case and it may take a little  
8           longer than that.

9           With that, are we completed?

10          MR. BERNIER: Yes.

11          THE COURT: We will then show this proceeding  
12          closed, and thank you all very much.

13          MR. REHWINKEL: That you.

14          MR. HERNANDEZ: Thank you, Your Honor.

15          (Whereupon, the proceedings concluded at 10:58  
16          a.m.)

17

18

19

20

21

22

23

24

25

## 1 CERTIFICATE OF REPORTER

2 STATE OF FLORIDA )  
3 COUNTY OF LEON )

4

5

6 I, DEBRA KRICK, Court Reporter, do hereby  
7 certify that the foregoing proceeding was heard at the  
8 time and place herein stated.

9

10 IT IS FURTHER CERTIFIED that I  
11 stenographically reported the said proceedings; that the  
12 same has been transcribed under my direct supervision;  
13 and that this transcript constitutes a true  
14 transcription of my notes of said proceedings.

15

16 I FURTHER CERTIFY that I am not a relative,  
17 employee, attorney or counsel of any of the parties, nor  
18 am I a relative or employee of any of the parties'  
19 attorney or counsel connected with the action, nor am I  
20 financially interested in the action.

21

22 DATED this 18th day of February, 2020.

23

24

25

26

27

28

29



---

30 DEBRA R. KRICK  
31 NOTARY PUBLIC  
32 COMMISSION #GG015952  
33 EXPIRES JULY 27, 2020